

180C SERIES OPERATION AND MAINTENANCE MANUAL



TABLE OF CONTENTS

FILTER BASICS	1
<i>Figure 1: 180C Series Filter – General Layout</i>	1
<i>Figure 2: 180C Series Filter – Assembled View</i>	1
<i>Figure 3: 180C Series Filter – Exploded View</i>	2
QUICK START GUIDE	3
<i>Figure 4: 180C Series Filter – Quick Start Guide</i>	3
INSTALLATION REQUIREMENTS	4
<i>Figure 5: 180C Series Filter – Installment Layout</i>	4
Couplings	4
Flush Line	4
Hydraulic Connections	5
Hydraulic Piston	5
FILTER PERFORMANCE	5
Normal Operation	5
<i>Figure 6: 180C Series Filter – Normal Operation</i>	5
Backwash Cycle	6
<i>Figure 7: 180C Series Filter – Backwash Cycle</i>	6
FLOW & PRESSURE REQUIREMENTS	7
<i>Figure 8: 180C Series Filter – Valve Flow Rates</i>	7
MAINTENANCE & SPARE PARTS	7
Startup	7
Shutdown	7
Periodic Maintenance	8
<i>Figure 9: 180C Series Filter – Inspection</i>	8
Particle Remover	9
<i>Figure 10: 180C Series Filter – Particle Remover</i>	9
Spare Parts	10
<i>Figure 11: 180C Series Filter – 2- 5-year Parts Maintenance</i>	10
Hydraulic Piston	11
<i>Figure 12: 180C Series Filter – Hydraulic Piston</i>	11
Piston Seal Replacement Instructions	12
<i>Figure 13: 180C Series Filter – Piston Seal Replacement</i>	12
Troubleshooting Guide	13
<i>Figure 14: 180C Series Filter – Trouble Shooting</i>	13
Screen Removal/Installation Instructions	14
<i>Figure 15: 180C Series Filter – Screen Removal</i>	14
<i>Figure 16: 180C Series Filter – Screen Installation</i>	15
INSTALLATION & WIRING	16
180C Series Filters Wiring	16
<i>Figure 17: 180C Series Filter – EC-2 Wiring</i>	16
2x180C Series Filters in Parallel	17
<i>Figure 18: 180C Series Filter – 2x180C in Parallel</i>	17
Wiring DC Drive	18
<i>Figure 19: 180C Series Filter – DC Drive Wiring Diagram</i>	18
WARRANTY	19

FILTER BASICS

The Forsta 180C (Compact) Series is a self-cleaning screen water filter. The major components include the Filter Housing (1), Coarse Screen pre-filter (11), Fine Screen filter element (2), Particle Remover (3), Hydraulic Piston (8), Backwash Valve (12)

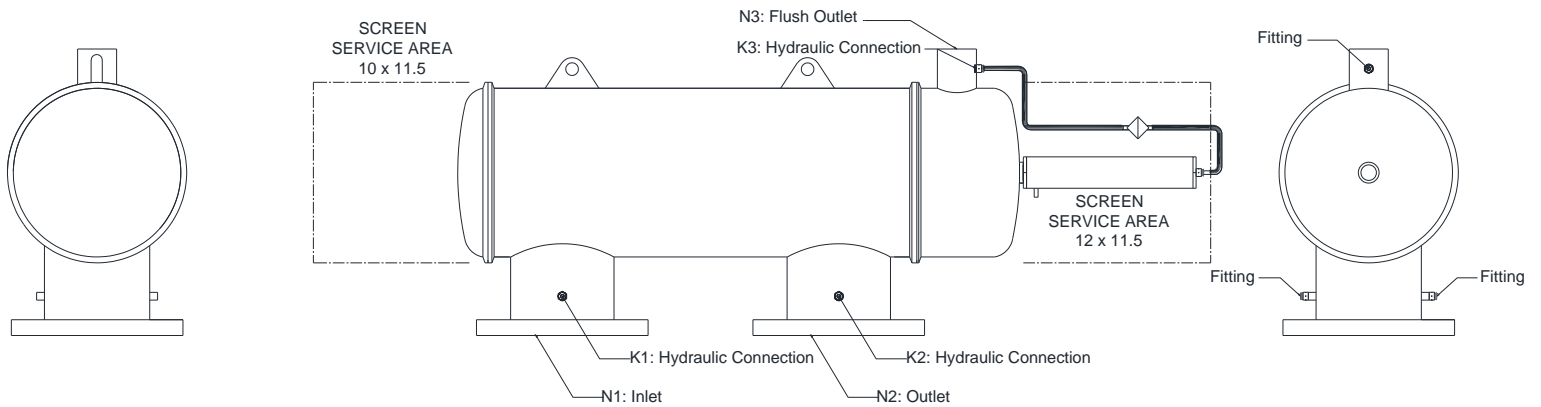

Figure 1: 180C Series Filter – General Layout

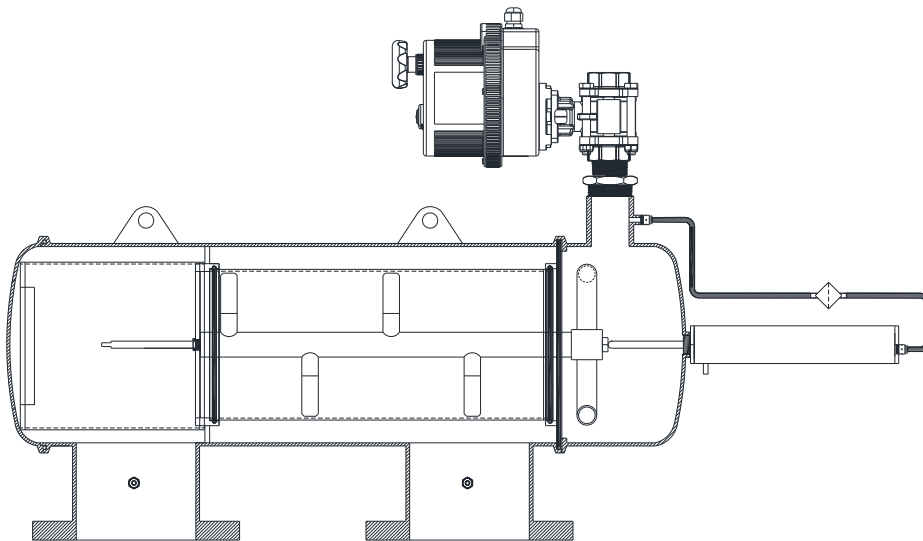

Figure 2: 180C Series Filter – Assembled View

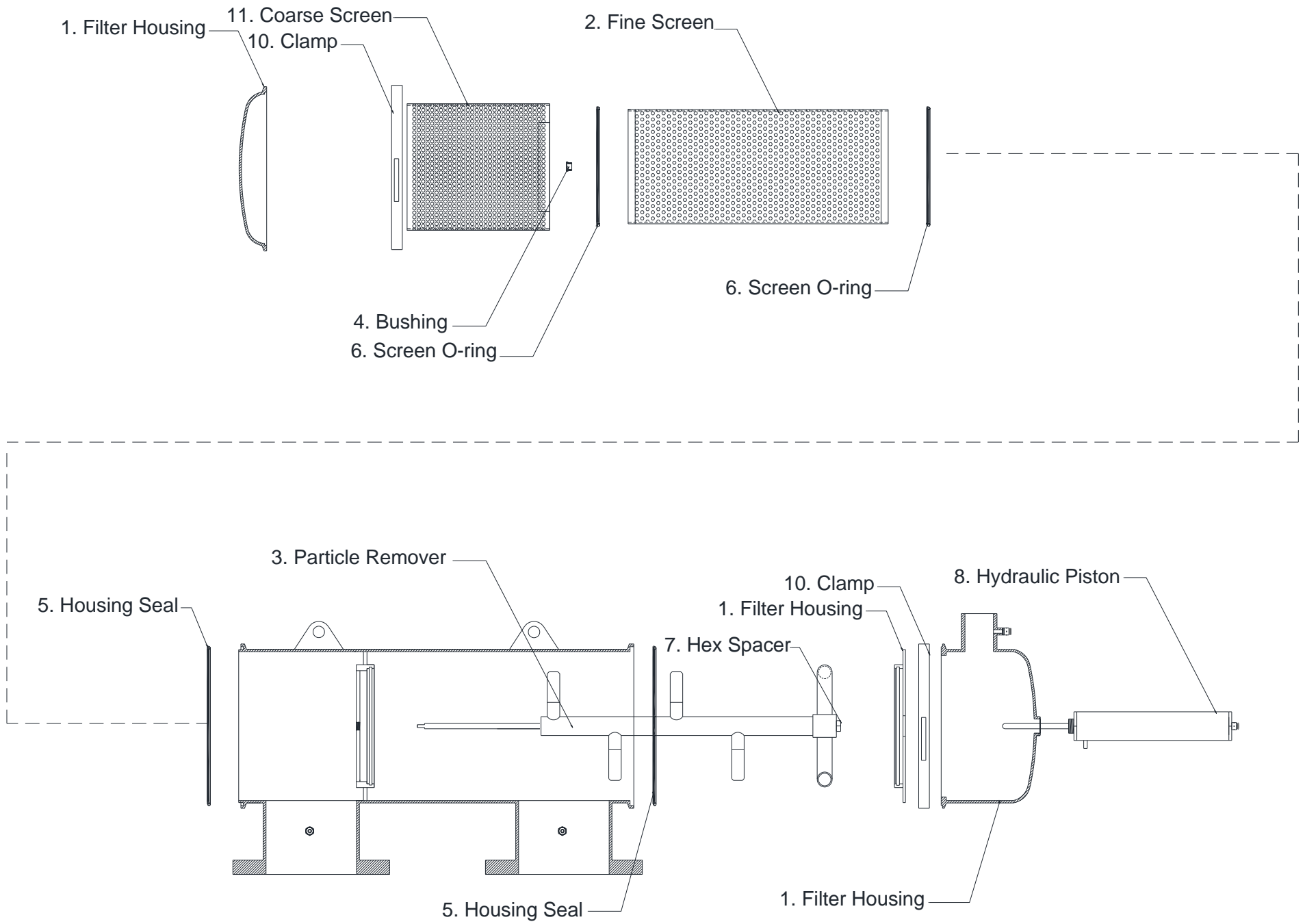

Figure 3: 180C Series Filter - Exploded View

QUICKSTART GUIDE

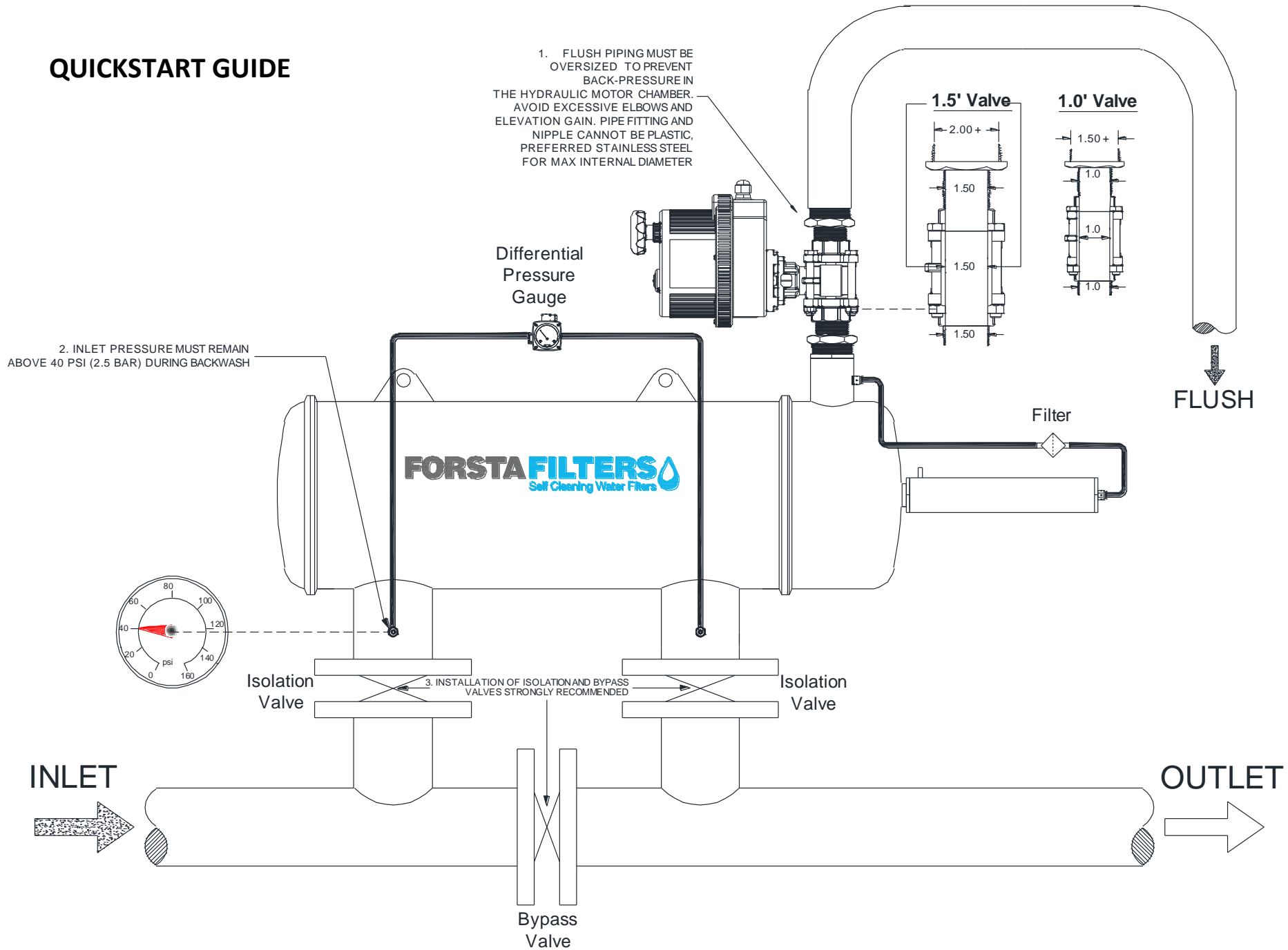

Figure 4: 180C Series Filter – Quick Start Guide

INSTALLATION REQUIREMENTS

180C Series filters may be mounted directly on the inlet (N1) and outlet (N2) flanges, and positioned in any orientation. As shown below in figure 4, isolation valves should be installed at the inlet and outlet, and a bypass valve should be installed between the flanges. This will allow the filter to be taken offline without disruption to water flow.

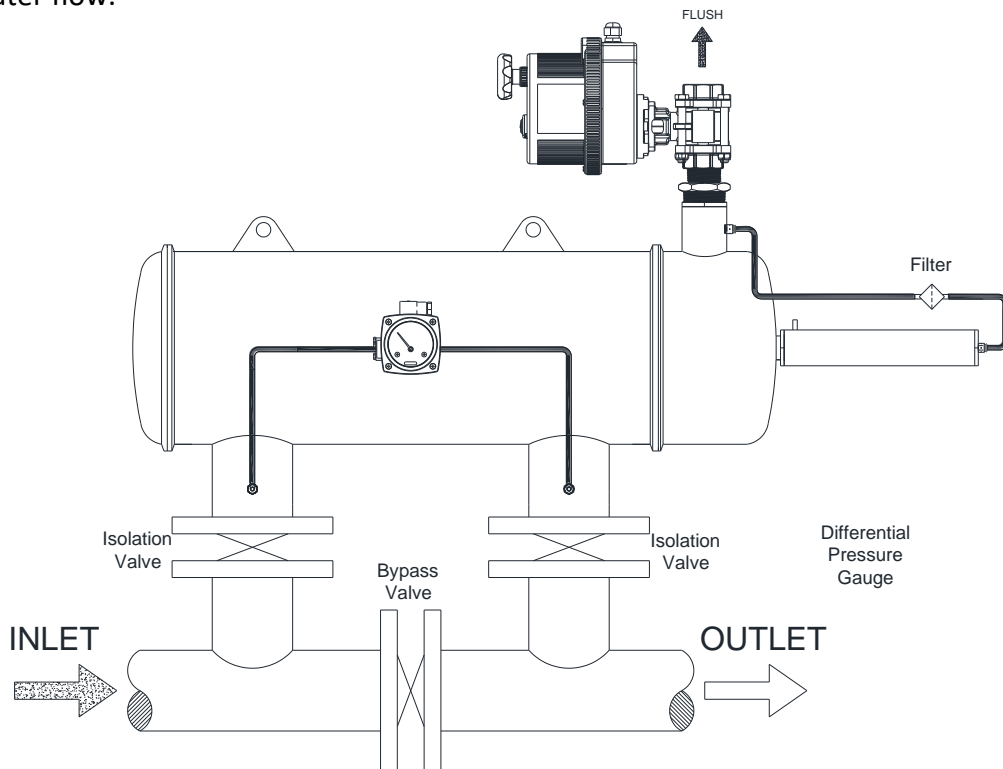

Figure 5: 180C Series Filter – Installment Layout

There should be adequate clearance around the filter to allow for easy maintenance access, including a minimum of 24" from the back (piston side). The minimum clearance on the front (cover) depends on the model. There must be enough room to remove the coarse screen and fine screen periodically.

Couplings

It is recommended to use the 1" threaded half couplings (N5) for air bleed-off during startup, and draining when taking the filter offline. Valves may be installed at both locations, otherwise the couplings remain plugged.

Flush Line

The piping for the flush valve must have no backpressure. It is strongly recommended to use oversized piping to accommodate this requirement. For example, if the 180C Series filter uses a 2" valve, the recommended pipe is a minimum of 3". For a 1" valve, 1.5" or 2" pipe must be used.

To minimize backpressure on the flush line, it is also important to avoid elevation gain in the flush line. Even small elevation gains will reduce the filter's ability to perform an effective backwash cycle. If flush water must be transported to higher elevation, it is recommended to pipe the flush line to a storage tank first, and then pump it out to higher elevation. Additionally, avoid any sharp bends and shifts of direction to allow a smooth flow of water during backwash.

Hydraulic Connection

Each flanged connection nozzle (N1 & N2) on the 180C Series filter has two ¼" threaded couplings. One may be used to install a pressure gauge or other sensor equipment. The other ¼" coupling will be used to connect hydraulic tubing from the differential pressure switch to the filter. The high-pressure line is fitted to the inlet, and low pressure fitted to the outlet.

Hydraulic Piston

The piston (8) is mounted on the domed end of the filter. ¼" tubing must be installed from the fitting located on the back of the piston to the hydraulic connection (K3) on the flush outlet (N3). A filter is installed on the hydraulic tubing to protect the piston.

FILTER PERFORMANCE

Normal Operation

During normal operation of the filter, dirty water enters through the inlet and passes through the coarse screen. Any abnormally large debris is caught here and prevented from possibly damaging the fine screen or particle remover.

Water then travels down the center of the filter and is strained across the fine screen. As water passes from inside the screen to outside, suspended particles are trapped on the fine screen and continue to buildup, eventually creating a drop in pressure at the outlet of the filter.

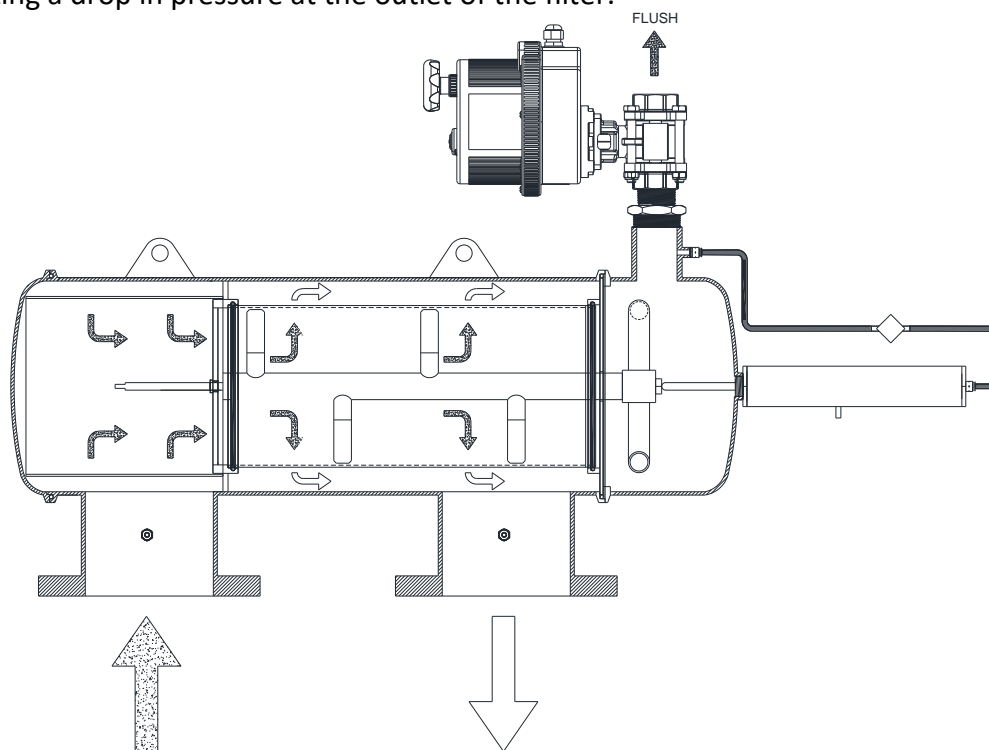

Figure 6: 180C Series Filter – Normal Operation

This drop in outlet pressure is monitored by the differential pressure gauge, which at seven PSID (pounds per square inch differential) sends a signal to the controller to initiate a backwash cycle.

Backwash Cycle

The controller opens the flush valve, which causes a drop in pressure in the hydraulic motor chamber. This creates a low-pressure path inside the particle remover, which acts as a vacuum at the end of the suction nozzles, removing the built-up debris from the inside of the fine screen.

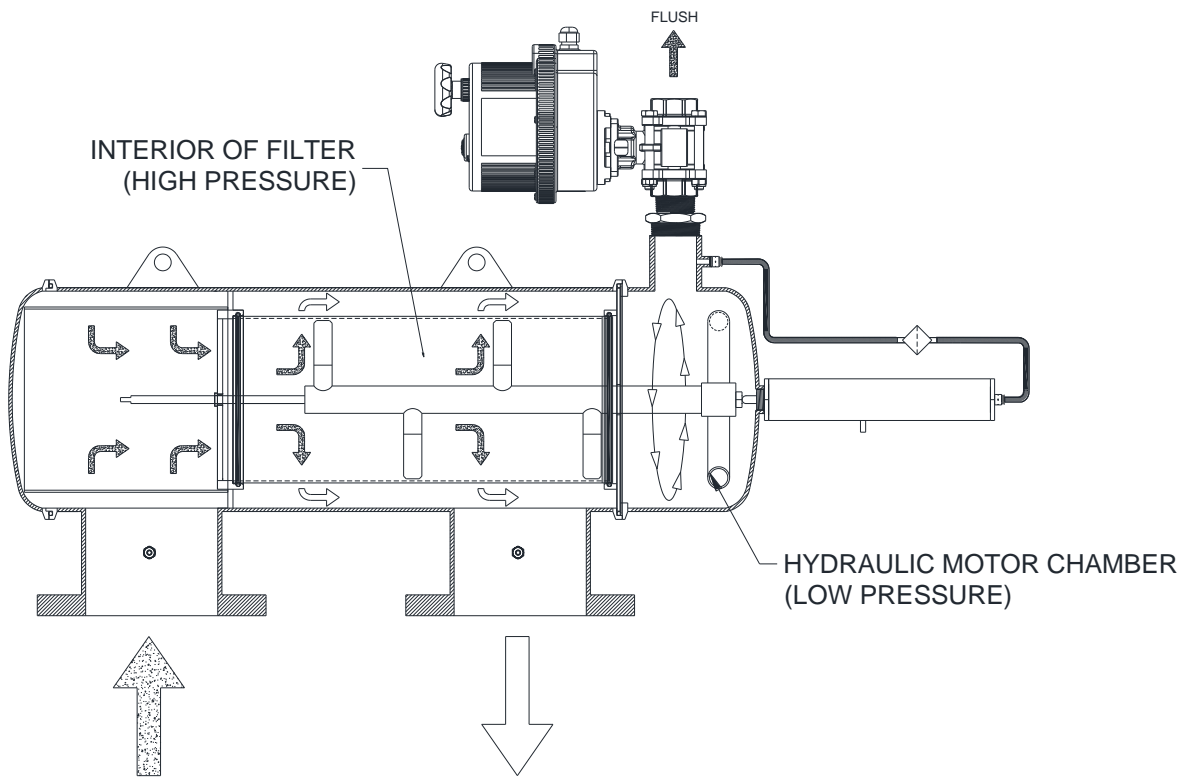

Figure 7: 180C Series Filter – Backwash Cycle

Water flows through the suction nozzles, down the interior of the particle remover, and out the hydraulic motor. The motor rotates the particle remover, enabling each suction nozzle to cover a radial strip of screen. And the pressure difference between the interior of the filter and the hydraulic motor chamber drives the particle remover toward the hydraulic piston.

The piston depressurizes during the backwash cycle, and expels the volume of water from its chamber. This acts as a timer, gradually allowing the particle remover to drive the piston rod into the piston, assuring that the suction nozzles cover the entire surface of the fine screen. When the piston reaches the end of its stroke, the backwash cycle is complete, and the flush valve closes. Pressure inside the hydraulic motor chamber normalizes with the rest of the filter, and the piston pushes the particle remover back to its original position.

After the piston and particle remover move back to their original positions, the filter returns to normal operation. During the entire backwash cycle, the main flow through the filter is never disrupted.

FLOW & PRESSURE REQUIREMENTS

Forsta 180C Series filters have a minimum pressure requirement of 40 PSI. This includes any pressure loss incurred during the backwash cycle. Therefore, the pump performance is a crucial component in determining whether the filter will perform correctly.

Pump manufacturers will provide the performance data in the form of a pump curve. This is a graph that plots pressure vs. flow rate. A pump is considered adequate for an application if it can maintain a minimum of 15 PSI while pumping the normal system flow AND the additional flow required during backwash. The additional flow depends on the filter model and what valve is used.

<u>Valve</u>	<u>Flow Rate</u>
1"	40 gpm
1.5"	100 gpm

Figure 8: 180C Series Filter – Valve Flow Rates

MAINTENANCE & SPARE PARTS

Startup

When pumping water through the Forsta 180C Series for the first time or after it has been empty, it is important to follow a correct sequence of valve actuation in order to prevent damage to the filter components.

With both isolation valves closed and the bypass valve open, the correct sequence is:

1. Slowly open the inlet isolation valve letting water flow into the filter. If installed, bleed out the air through a valve on the top of the filter body. Let the entire filter fill with water before moving to the next step.
2. Close the bypass valve.
3. Open the outlet isolation valve.

If it is not an option to close the bypass valve momentarily before opening the outlet valve, then both may be actuated simultaneously.

Shutdown

To remove the filter from operation, reverse the steps used for startup.

1. Close the outlet valve.
2. Open the bypass valve
3. Close the inlet valve, and slowly open the drain valve on the bottom of the filter housing. There will be residual pressure in the tank still, so use caution when draining.

If it is not an option to close the outlet valve momentarily before opening the bypass, then both may be actuated simultaneously.

Periodic Maintenance

Every six months or whenever pumps or water flow is shutdown, it is recommended to open and inspect the filter components. Access to the internal components is through the front cover and service port (N4).

Remove the piston from the back plate and drain the water from the piston chamber. Verify that the piston rod is moving smoothly in and out, and inspect the piston tip for wear.

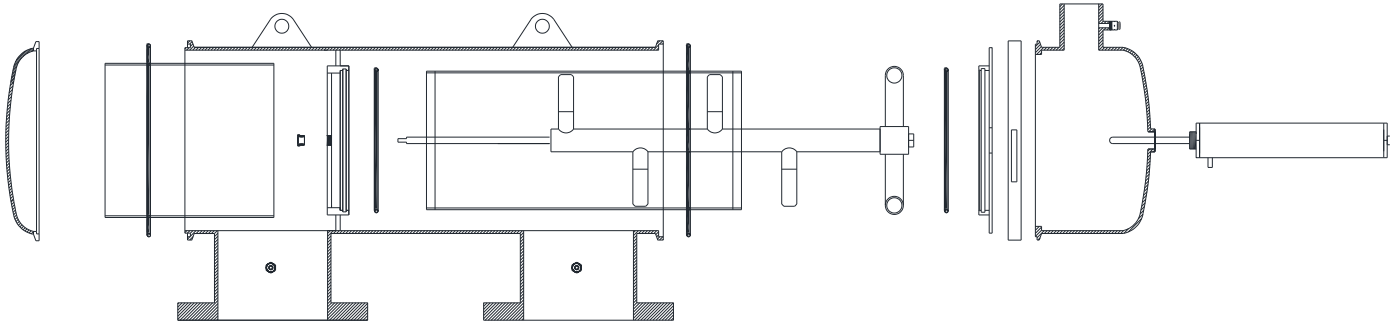

Figure 9: 180C Series Filter - Inspection

Remove the hydraulic motor from the rest of the particle remover by accessing it through the service port. It has a left-hand thread, so it must be turned to the right to loosen it.

Remove the screen and particle remover, using the front cover for access. Both should be extracted in one piece. Separate the two items and inspect both for damage. The screen mesh and bushing should be inspected for wear.

Also inspect the particle remover rod and suction nozzles for wear.

When taking care of the filter, also perform the same periodic maintenance on the piston itself. A step-by-step description of disassembling the piston for maintenance and replacement of parts is displayed on page 12 of the manual. Furthermore, an animated video of the individual parts being assembled and disassembled will be provided in the “180C series” link on our website

Particle Remover

3 Particle Remover

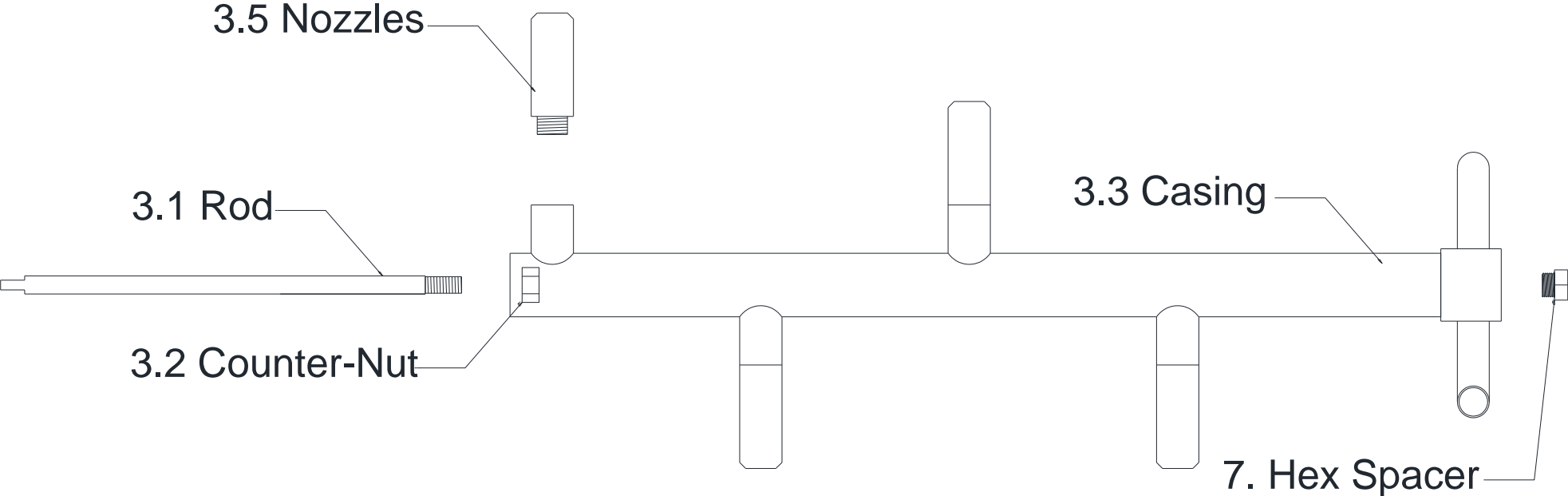

Figure 10: 180C Series Filter – Particle Remover

Spare Parts

Spare parts for maintenance for **two** years include:

Part Number	Description	Qty
1.7-90/180C/LP180C-UHMWPE	Plate Bushing	1
1.8-90/180C/LP180C-UHMWPE	Plate Bushing O-ring	1
10-90/180C/LP180C	Stainless Steel Clamp	2
16-1/4	Mini Filter	1
17-Fitting/Tubing	Fitting Tube	1
18-D/P-MW-522A	Pressure Differential Switch	1
3.5-180C	Suction Nozzles	4
4-90/180C/LP180C-VHL	Bushing	1
5-90/180C/LP180C	Housing Seal	2
6-90/180C/LP180C	Screen O-Ring	2
7-90/180C-316L-VES	Spacer	1
8K-90/180C	Piston Repair Kit	1

Spare parts for maintenance for **five** years include:

Part Name	Qty
Plate bushing (1.7)	2
Plate bushing o- ring (1.8)	2
Fine Screen (2)	1
Particle Remover (3)	1
Particle Remover rod (3.1)	1
Suction Nozzles (3.5)	2 Sets
Bushing (4)	2
Cover Seal (5)	2
Screen O-rings (6)	4
Hex Spacer (7)	2
Hydraulic piston (8)	1
Shaft tip (8.9)	2
Piston Seal Kit (8K)	2
Valve (12)	1
Mini-Filter (16)	2
Differential Pressure Gauge (18)	2
Tubing & fitting	2

Figure 11: 180C Series Filter – 2- and 5-Year Parts Maintenance

Hydraulic Piston

8

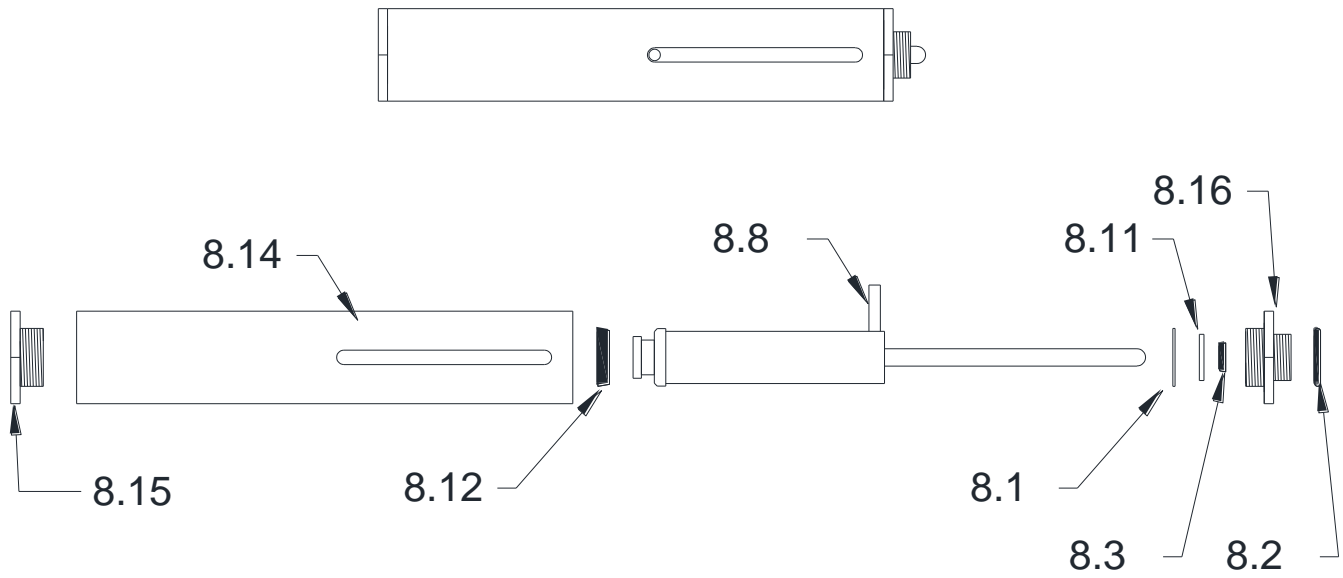

ITEM	PART NUMBER
Hydraulic Piston	8
Snap Ring	8.1
Head Ring	8.2
Shaft U-cup	8.3
Piston Pin	8.8
U-cup Holder	8.11
Casing U-cup	8.12
Casing	8.14
Casing Cap	8.15
Piston Head	8.16

Figure 12: 180C Series Filter – Part List – Hydraulic Piston

Piston Seal Replacement Guide

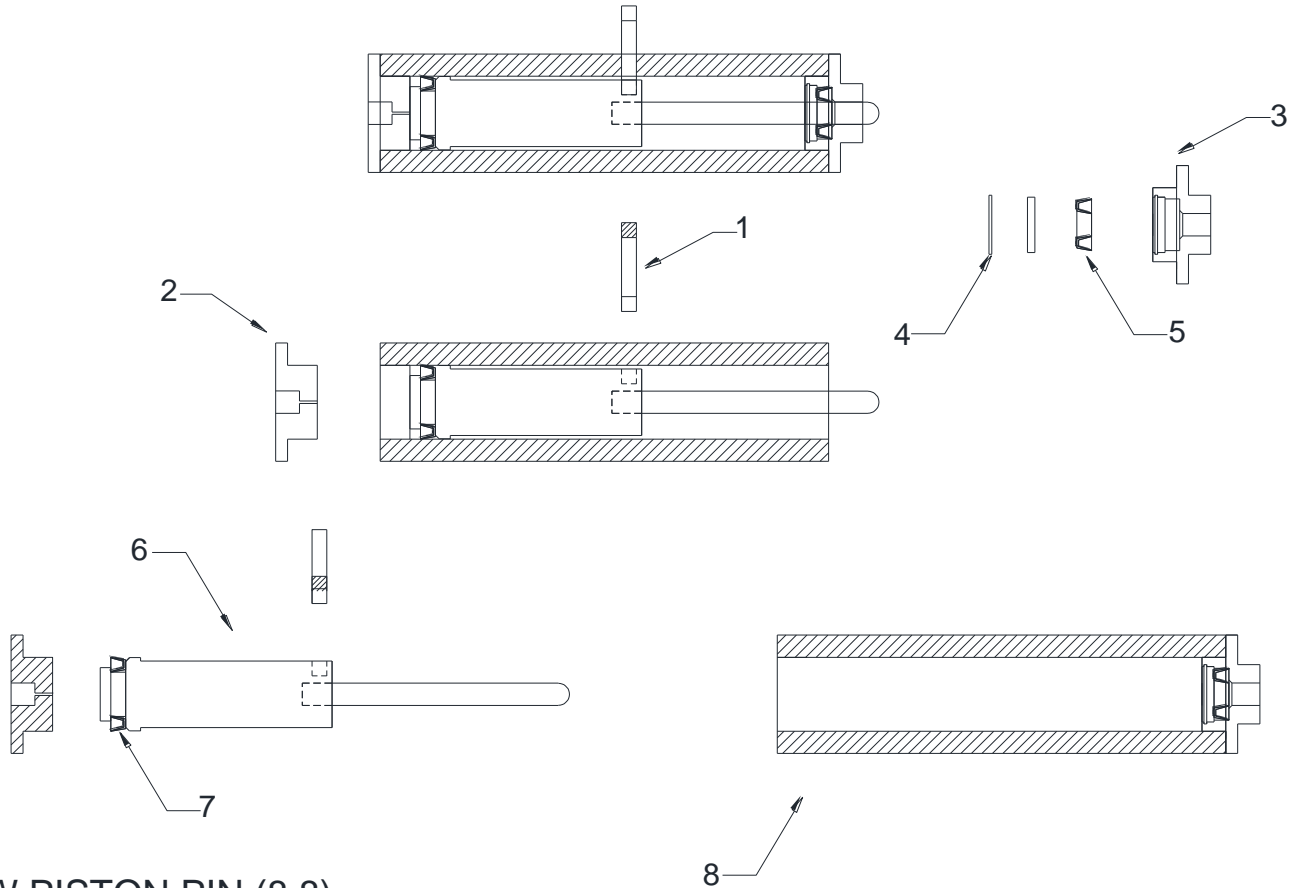

1. UNSCREW PISTON PIN (8.8)
2. UNSCREW PISTON CAP (8.15)
3. UNSCREW PISTON HEAD (8.16)
4. USE C-RING PLIERS TO REMOVE CLAMP AND HEAD WASHER (8.1)
5. REPLACE SHAFT U-CUP (8.3)
6. REMOVE U-CUP HOLDER (8.11)
7. REPLACE CASING U-CUP (8.12)
8. CLEAN AND LUBRICATE CASING (8.14) USING MOLYKOTE 111 OR SILICONE GREASE

Figure 13: 180C Series Filter – Piston Seal Replacement

Troubleshooting Guide

1. PRESSURE / 2. BACKWASH PRESSURE

During normal operation, record the pressure reading at inlet connection K1. If the pressure is below 40 psi, this is your problem.

During backwash, record the pressure reading at inlet connection K1 (flush valve open). If the pressure is below 40 psi, this is your problem.

Solution

Increase system pressure by:

- Choking the outlet of the filter.
- Ramping up pump.
- Replacing pressure gauge if it is defective.

3. FLUSH PORT

Record the pressure reading at flush outlet connection K3 during backwash.

If no pressure gauge is installed on K3, add a tee ("T") connection to install gauge.

If the pressure does not read 0 psi during backwash, this is your problem.

Solution

- Re-pipe the flush line to prevent back-pressure. Remove elbows, elevation gain, and oversize the pipe.
- Flush directly to a nearby tank.
- Increase flush valve size.

4. MINI FILTER

Inspect mini-filter located on the piston tubing line. If the mini-filter is clogged, this is your problem.

Solution

- Wash the mini-filter.

5. HYDRAULIC PISTON

Inspect the hydraulic piston (8). Verify that the rod can smoothly move back and forth, and that the pin moves the entire length of the slot.

Solution

- Open the brass hex caps and inspect the rubber seals for wear. They may need to be replaced.
- Check that the hex cap (8.15) has a small hole through it to allow water to flow out of the piston. If this orifice is obstructed, remove debris.

6. PARTICLE REMOVER

Inspect the internal components for smooth operation. If the particle remover is jammed, this is your problem.

Solution

- Bypass the filter and relieve pressure. Open the connection clamp, and remove the top section of the filter. The particle remover should rotate freely inside the center of the plate.
- Remove the plate and inspect the particle remover. The rod should be inserted into the bushing near the inlet of the filter. There should be clearance between the suction nozzles and the screen.
- Check for any severe damage or wear on any of the components.



180C SERIES FILTER - NORMAL OPERATION

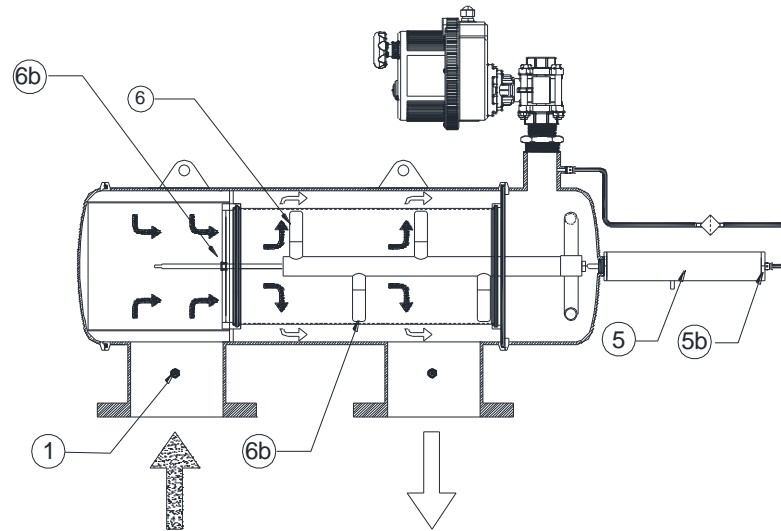

180C SERIES FILTER - BACKWASH CYCLE

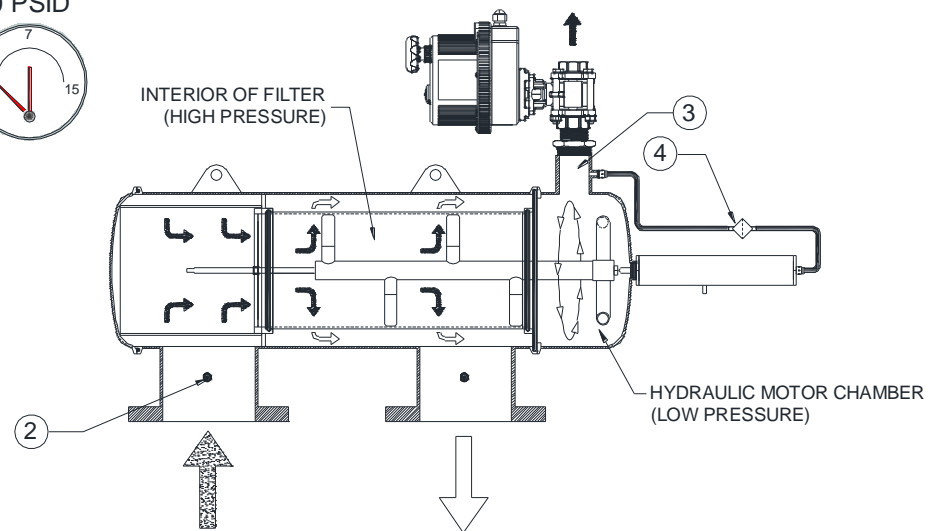
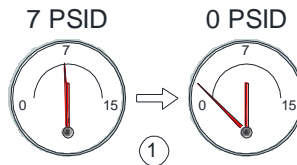
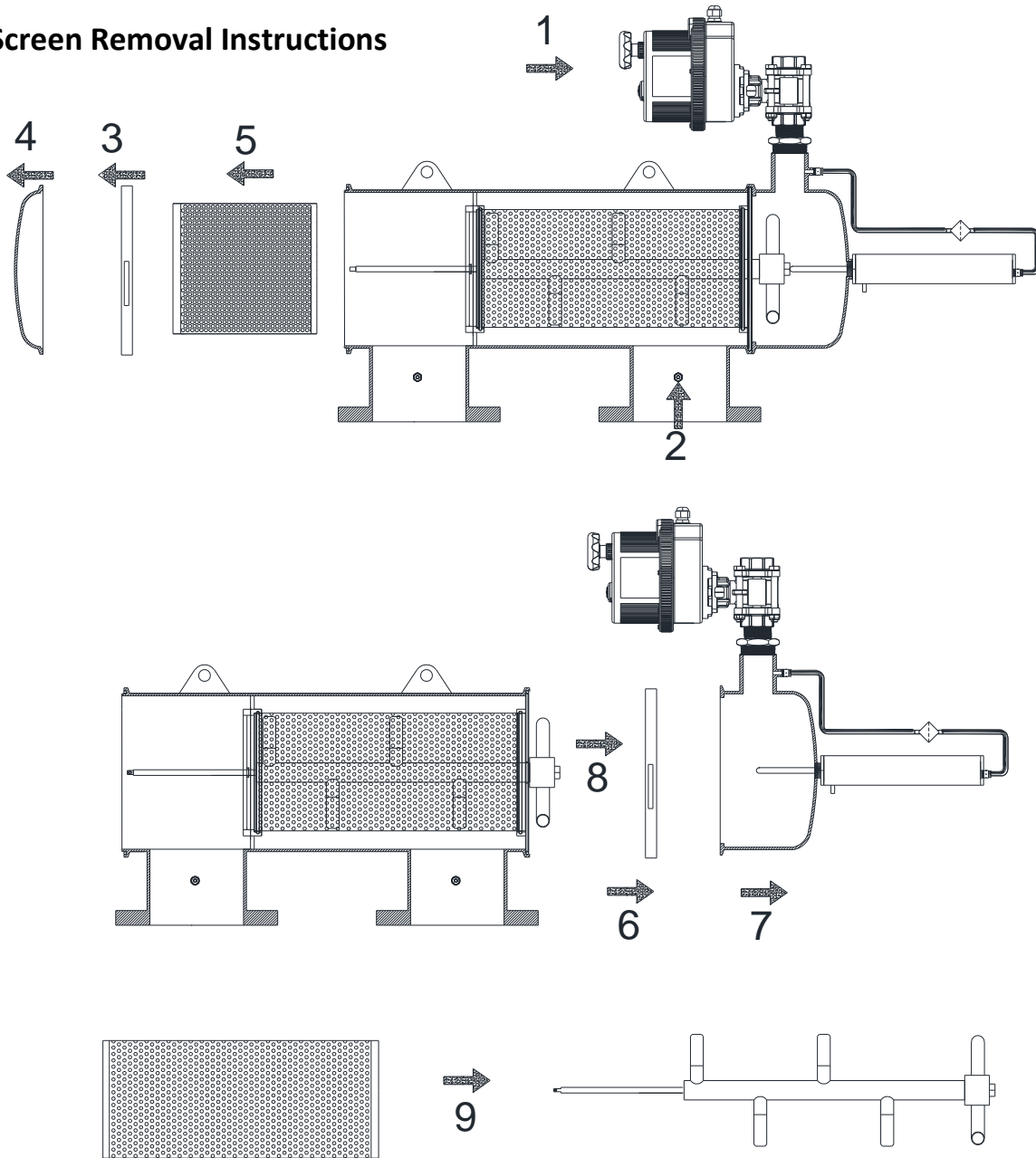

Figure 14: 180C Series Filter – Troubleshooting

Screen Removal Instructions



1. Relieve pressure in the filter body by first running a backwash cycle. Monitor the pressure gauge and stop once 0 PSI is reached.
2. Drain the filter body by removing the fittings on the inlet and outlet pipe.
3. Remove the clamp holding the front cap and filter body together
4. Remove the front cap
5. Remove the coarse screen
6. Remove the clamp on the other side of the filter body
7. Remove the piston, valve and piston end cover as a whole
8. Remove the particle remover and fine screen unit as a whole
9. Separate the particle remover from the fine screen

Figure 15: 180C Series Filter – Screen Removal

Screen Installation Instructions

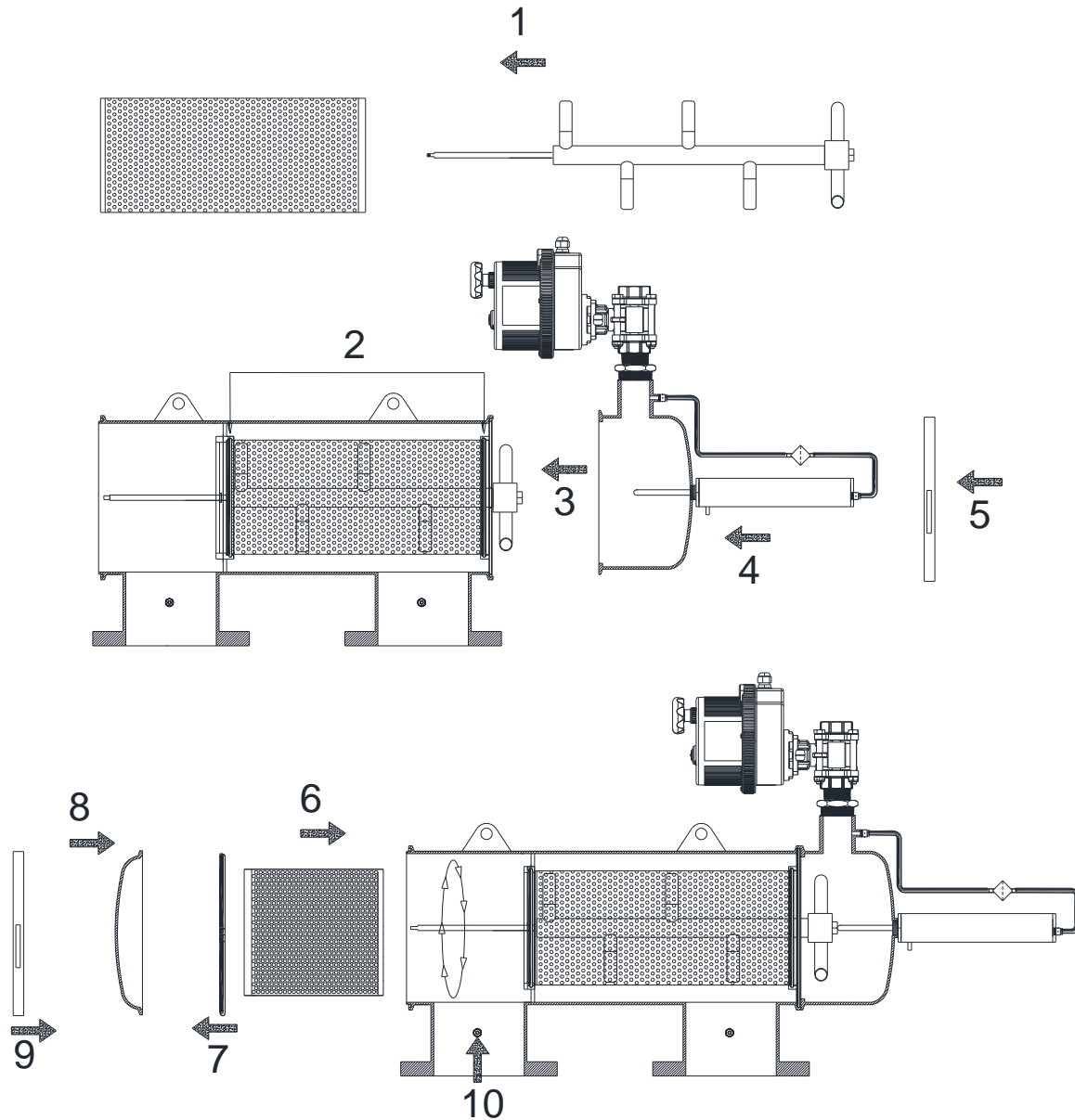

1. Insert the particle remover into the screen, guiding the rod into the screen bushing.
2. Lubricate the screen O-rings with NSF 61 approved silicone grease before installation
3. Lift the fine screen with the particle remover as one unit and insert into the filter body. Guide the particle remover through the opposite end of the filter body.
4. Place the opposite end Lid with piston assembly back onto the filter body
5. Clamp the lid with piston assemble onto the filter body
6. With the same method as above, insert the coarse screen into the filter body and secure it in place.
7. Lubricate the screen O-ring with NSF 61 approved silicone grease and install in the slid on the front cover
8. Place the front cover onto the filter body
9. Place the clamp between the front cover and the filter body to secure the two together
10. Thread fitting back into its respectful spot and run the filter body inspecting everything before putting it back into full use

Figure 16: 180C Series Filter – Screen Installation

INSTALLATION & WIRING

180C Series Filters Wiring

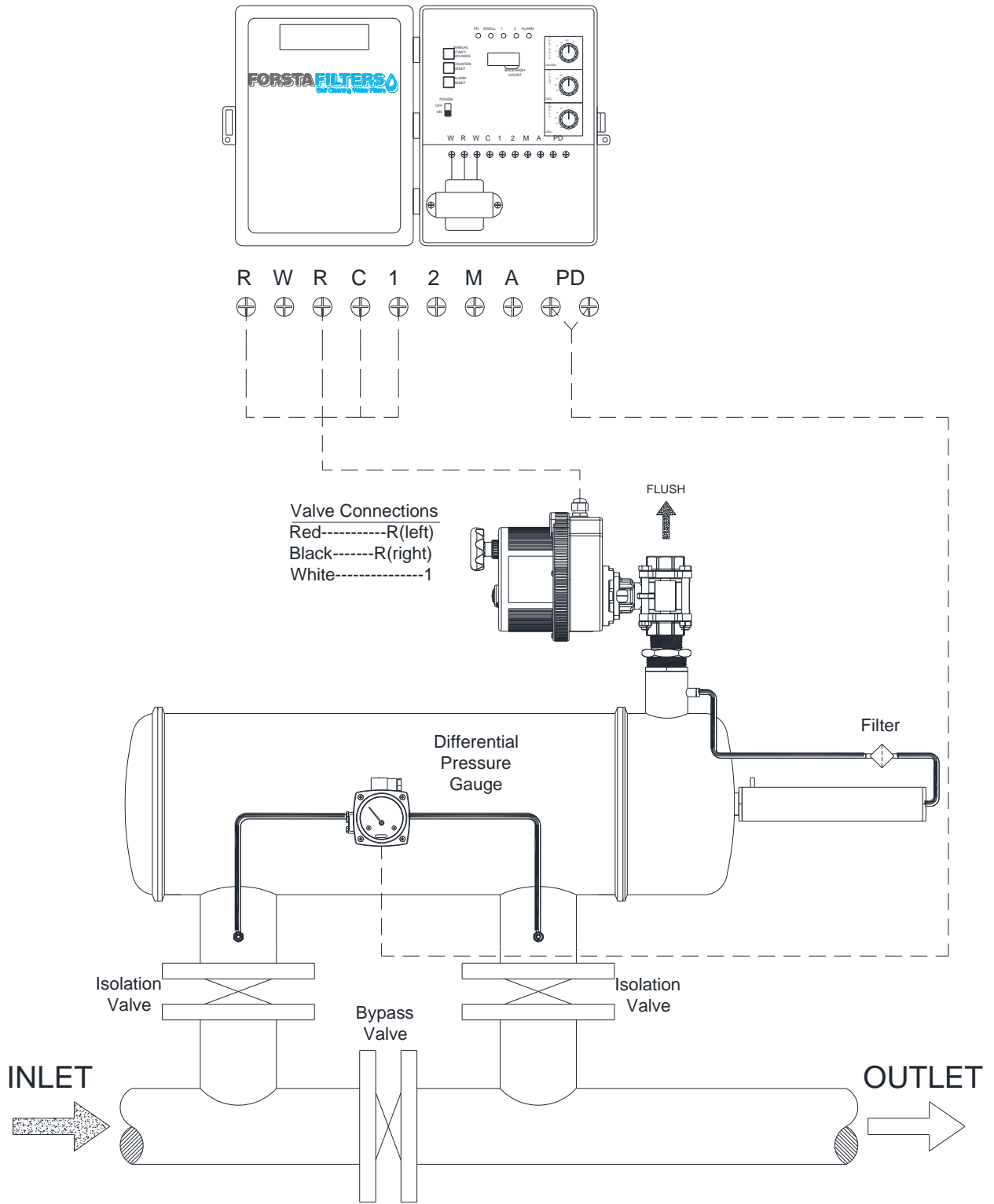

Figure 17: 180C Series Filter – EC-2 Wiring

2x180C Series Filters in Parallel

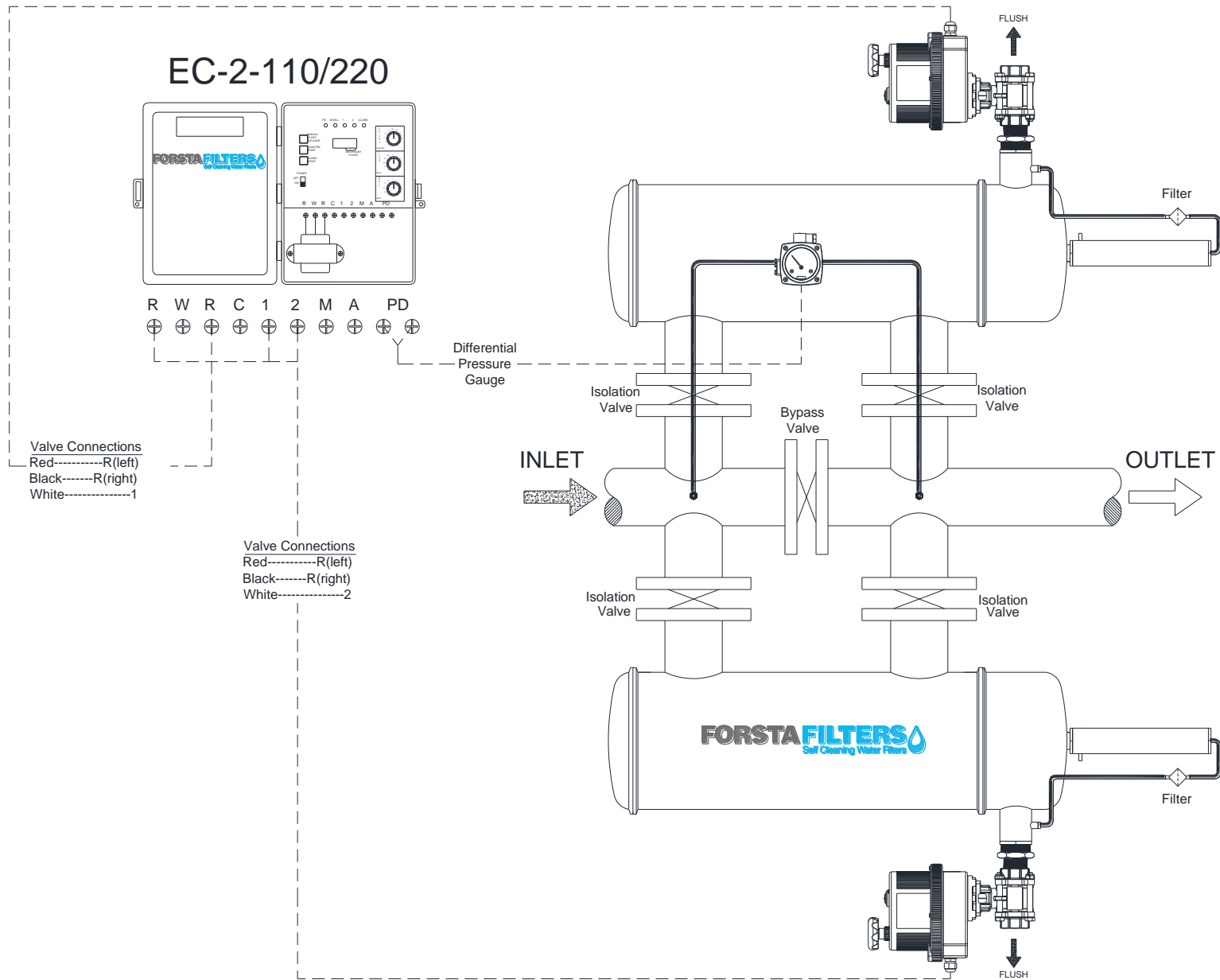

Figure 18: 180C Series Filter – 2x180C in Parallel

WARRANTY

Forsta Filters guarantees all self-cleaning water filters, components, and accessories free of defects for one year from the date of installation, or 18 months from the date of original shipment. Forsta will replace any part found defective during the warranty period, provided the equipment in question was handled, installed, and operated in accordance with the operation and maintenance manual and sound engineering practices. Forsta Filters assumes no liability for incidental or consequential damage resulting from the use of its products, services, or data. Liability is limited to replacement or repair of products provided by Forsta Filters, and no agent or sales representative has authority to extend the warranty period without the express written consent of Forsta Filters, Inc. Shipping charges for returned equipment will be at the expense of the purchaser, and all returned equipment must be sent to Forsta Filters