

## LP180-FRP SERIES OPERATION AND MAINTENANCE MANUAL

---



# TABLE OF CONTENTS

<b>FILTER BASICS</b> .....	1
<i>Figure 1: LP180-FRP Series Filter – General Layout</i> .....	1
<i>Figure 2: LP180-FRP Series Filter – Assembled View</i> .....	1
<i>Figure 3: LP180-FRP Series Filter – Exploded View</i> .....	2
<b>QUICK START GUIDE</b> .....	3
<i>Figure 4: LP180-FRP Series Filter – Quick Start Guide</i> .....	3
<b>INSTALLATION REQUIREMENTS</b> .....	4
<i>Figure 5: LP180-FRP Series Filter – Installment Layout</i> .....	4
Couplings .....	4
Flush Line .....	4
Hydraulic Connections .....	5
Hydraulic Piston .....	5
<b>FILTER PERFORMANCE</b> .....	5
Normal Operation .....	5
<i>Figure 6: LP180-FRP Series Filter – Normal Operation</i> .....	5
Backwash Cycle .....	6
<i>Figure 7: LP180-FRP Series Filter – Backwash Cycle</i> .....	6
<b>FLOW &amp; PRESSURE REQUIREMENTS</b> .....	7
<i>Figure 8: LP180-FRP Series Filter – Valve Flow Rates</i> .....	7
<b>MAINTENANCE &amp; SPARE PARTS</b> .....	7
Startup .....	7
Shutdown .....	7
Periodic Maintenance .....	8
<i>Figure 9: LP180-FRP Series Filter – Inspection</i> .....	8
Particle Remover .....	9
<i>Figure 10: LP180-FRP Series Filter – Particle Remover</i> .....	9
Spare Parts .....	10
<i>Figure 11: LP180-FRP Series Filter – 2- 5-year Parts Maintenance</i> .....	10
Hydraulic Piston .....	11
<i>Figure 12: LP180-FRP Series Filter – Hydraulic Piston</i> .....	11
Piston Seal Replacement Instructions .....	12
<i>Figure 13: LP180-FRP Series Filter – Piston Seal Replacement</i> .....	12
Troubleshooting Guide .....	13
<i>Figure 14: LP180-FRP Series Filter – Trouble Shooting</i> .....	13
Screen Removal/Installation Instructions .....	14
<i>Figure 15: LP180-FRP Series Filter – Screen Removal</i> .....	14
<i>Figure 16: LP180-FRP Series Filter – Screen Installation</i> .....	15
<b>INSTALLATION &amp; WIRING</b> .....	16
LP180-FRP Series Filters Wiring .....	16
<i>Figure 17: LP180-FRP Series Filter – EC-2 Wiring</i> .....	16
2xLP180-FRP Series Filters in Parallel .....	17
<i>Figure 18: LP180-FRP Series Filter – 2xLP180-FRP in Parallel</i> .....	17
<b>WARRANTY</b> .....	18

# FILTER BASICS

The Forsta LP180-FRP Series is a self-cleaning screen water filter. The major components include the Filter Housing (1), Coarse Screen pre-filter (11), Fine Screen filter element (2), Particle Remover (3), Hydraulic Piston (8), Backwash Valve (12), AND Electric Motor (13.1).

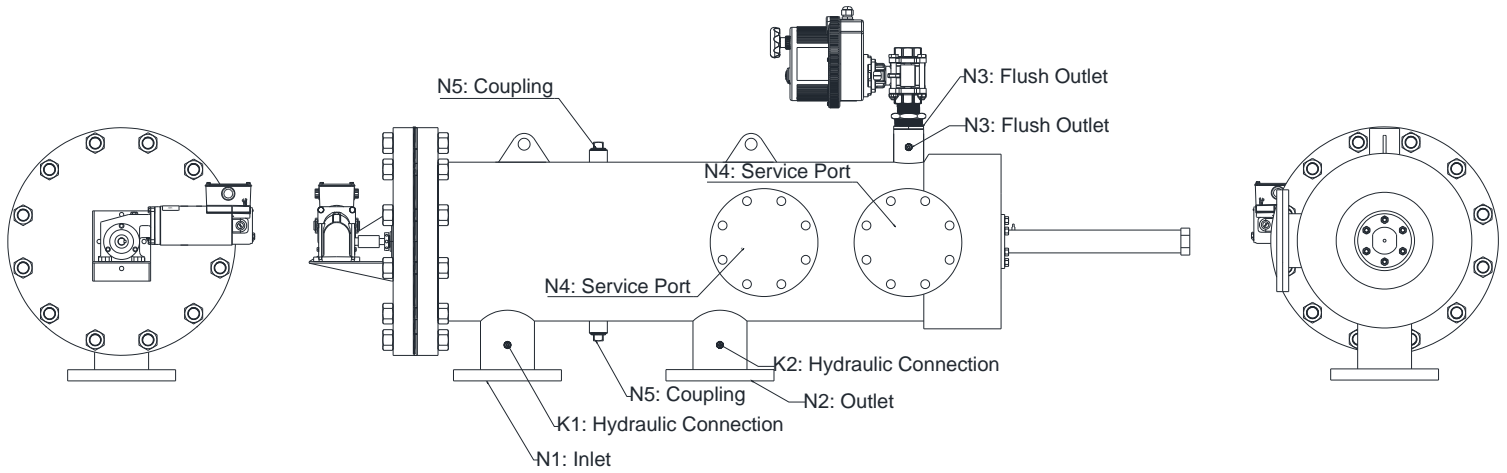

Figure 1: LP180-FRP Series Filter – General Layout

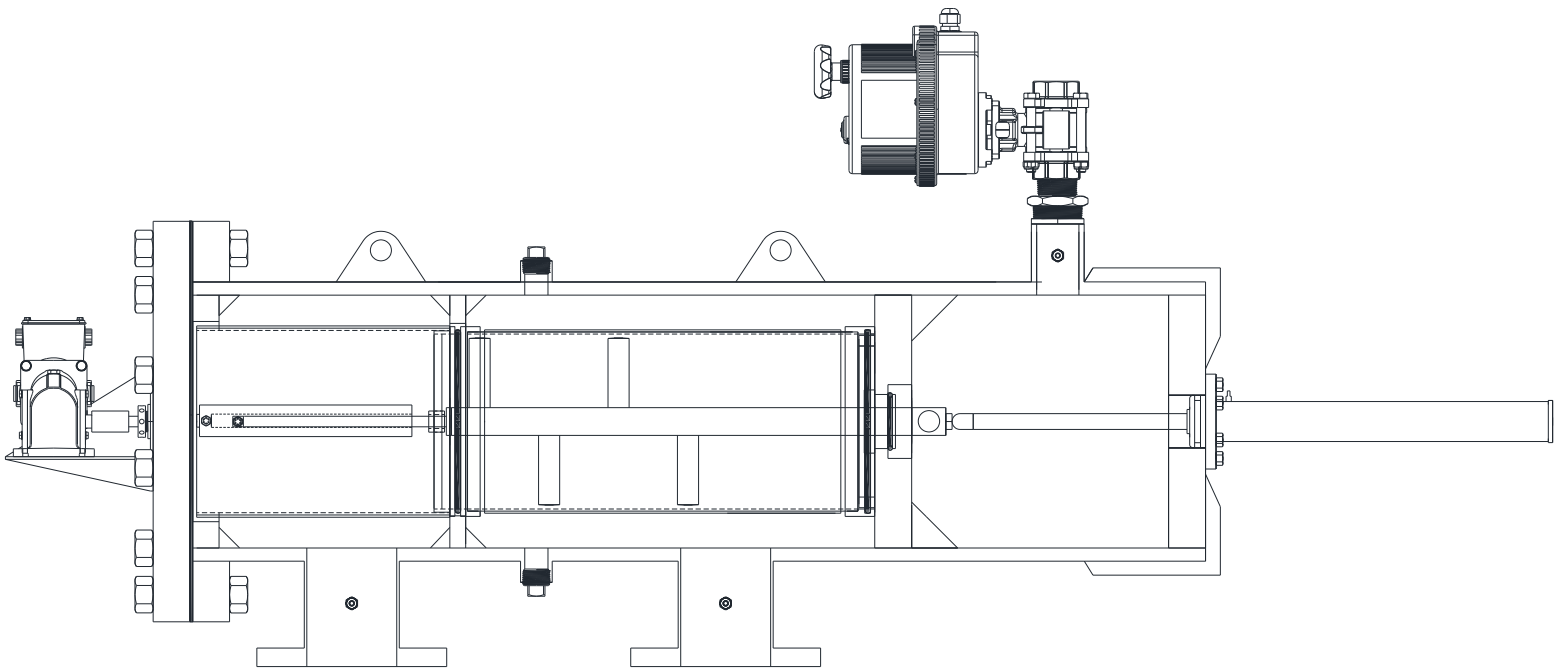

Figure 2: LP180-FRP Series Filter – Assembled View

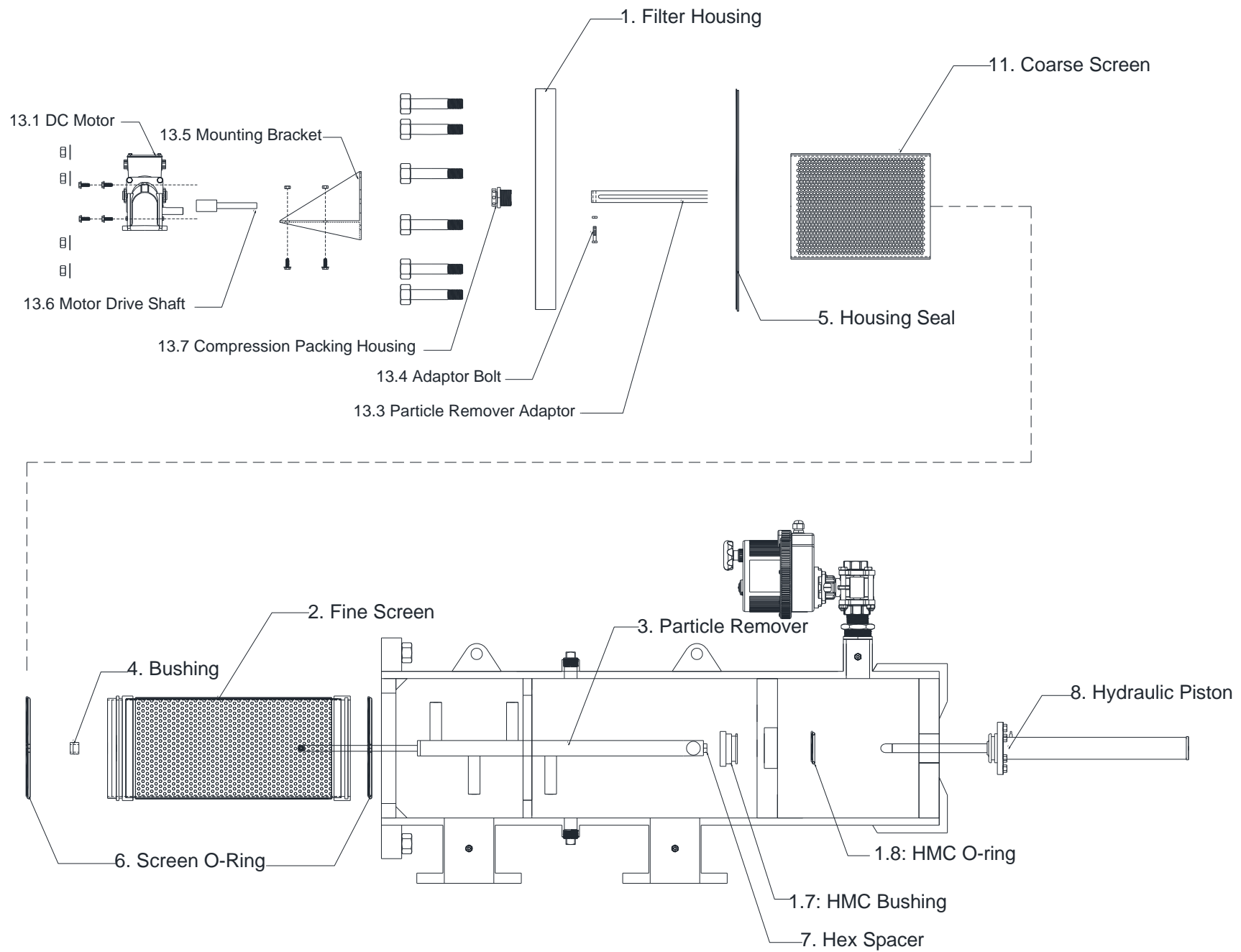
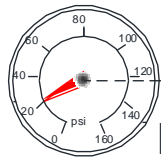

Figure 3: LP180-FRP Series Filter - Exploded View

# QUICKSTART GUIDE

1. FLUSH PIPING MUST BE OVERSIZED TO PREVENT BACK-PRESSURE IN THE HYDRAULIC MOTOR CHAMBER. AVOID EXCESSIVE ELBOWS AND ELEVATION GAIN. PIPE FITTING AND NIPPLE CANNOT BE PLASTIC, PREFERRED STAINLESS STEEL FOR MAX INTERNAL DIAMETER

2. INLET PRESSURE MUST REMAIN ABOVE 20 PSI (1.38 BAR) DURING BACKWASH



Isolation Valve

Isolation Valve

Bypass Valve

3. INSTALLATION OF ISOLATION AND BYPASS VALVES STRONGLY RECOMMENDED

INLET

OUTLET

Differential Pressure Gauge

Filter

FLUSH

2' Valve

1.5' Valve

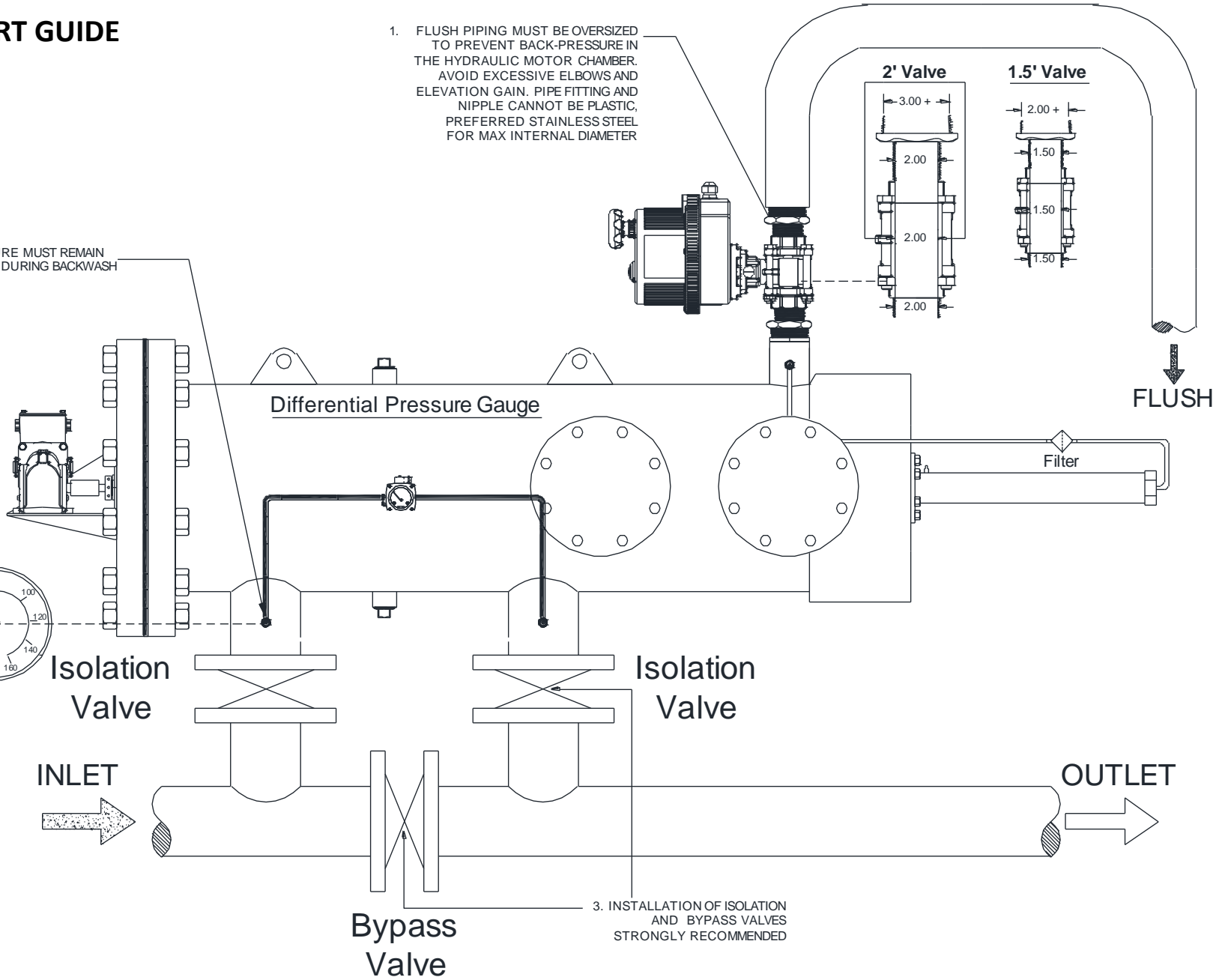

Figure 4: LP180-FRP Series Filter – Quick Start Guide

## INSTALLATION REQUIREMENTS

LP180-FRP Series filters may be mounted directly on the inlet (N1) and outlet (N2) flanges, and positioned in any orientation. As shown below in figure 4, isolation valves should be installed at the inlet and outlet, and a bypass valve should be installed between the flanges. This will allow the filter to be taken offline without disruption to water flow.

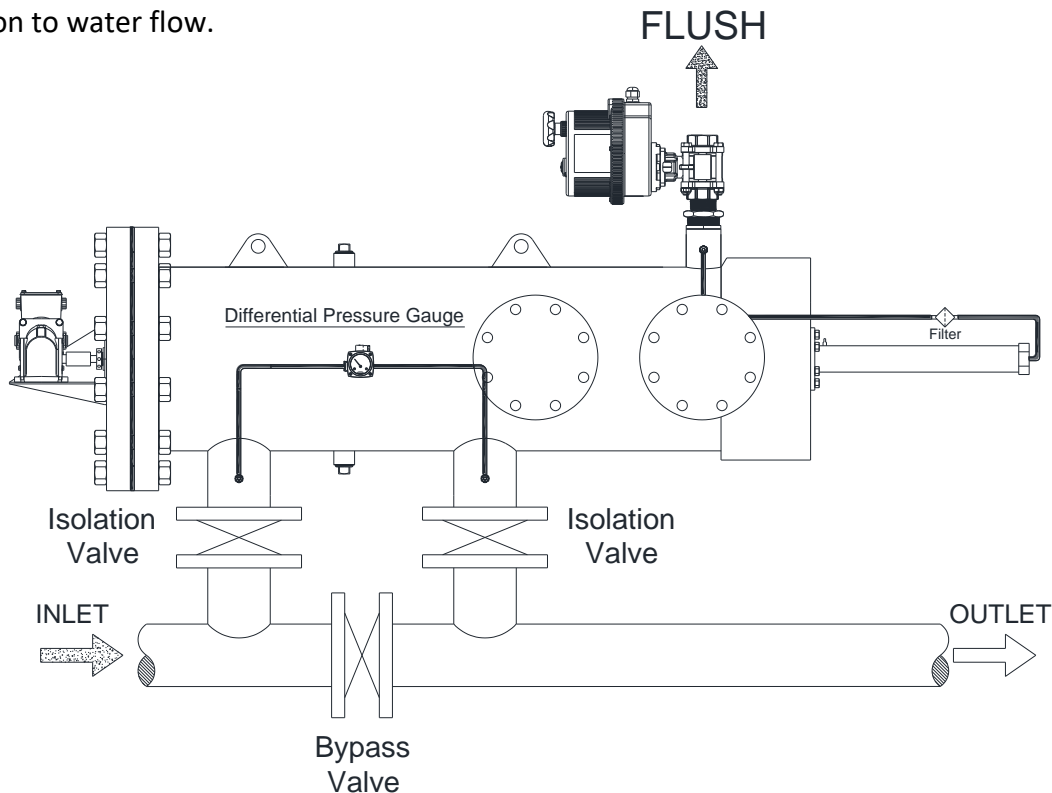

Figure 5: LP180-FRP Series Filter – Installment Layout

There should be adequate clearance around the filter to allow for easy maintenance access, including a minimum of 24" from the back (piston side). The minimum clearance on the front (cover) depends on the model. There must be enough room to remove the coarse screen and fine screen periodically.

### Couplings

It is recommended to use the 1" threaded half couplings (N5) for air bleed-off during startup, and draining when taking the filter offline. Valves may be installed at both locations, otherwise the couplings remain plugged.

### Flush Line

The piping for the flush valve must have no backpressure. It is strongly recommended to use oversized piping to accommodate this requirement. For example, if the LP180-FRP Series filter uses a 2" valve, the recommended pipe is a minimum of 3". For a 1" valve, 1.5" or 2" pipe must be used.

To minimize backpressure on the flush line, it is also important to avoid elevation gain in the flush line. Even small elevation gains will reduce the filter's ability to perform an effective backwash cycle. If flush water must be transported to higher elevation, it is recommended to pipe the flush line to a storage tank first, and then pump it out to higher elevation. Additionally, avoid any sharp bends and shifts of direction to allow a smooth flow of water during backwash.

## Hydraulic Connection

Each flanged connection nozzle (N1 & N2) on the LP180-FRP Series filter has two ¼" threaded couplings. One may be used to install a pressure gauge or other sensor equipment. The other ¼" coupling will be used to connect hydraulic tubing from the differential pressure switch to the filter. The high-pressure line is fitted to the inlet, and low pressure fitted to the outlet.

## Hydraulic Piston

The piston (8) is mounted on the domed end of the filter. ¼" tubing must be installed from the fitting located on the back of the piston to the hydraulic connection (K3) on the flush outlet (N3). A filter is installed on the hydraulic tubing to protect the piston.

## FILTER PERFORMANCE

### Normal Operation

During normal operation of the filter, dirty water enters through the inlet and passes through the coarse screen. Any abnormally large debris is caught here and prevented from possibly damaging the fine screen or particle remover.

Water then travels down the center of the filter and is strained across the fine screen. As water passes from inside the screen to outside, suspended particles are trapped on the fine screen and continue to buildup, eventually creating a drop in pressure at the outlet of the filter.

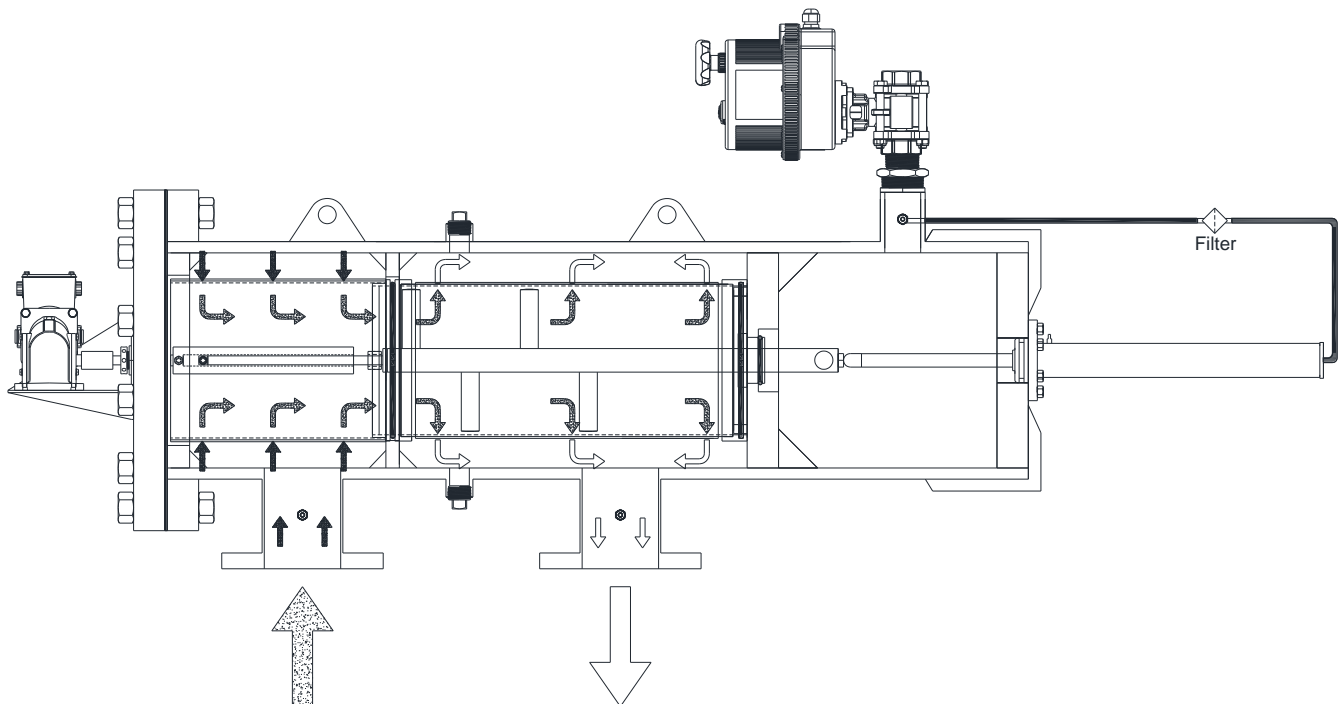
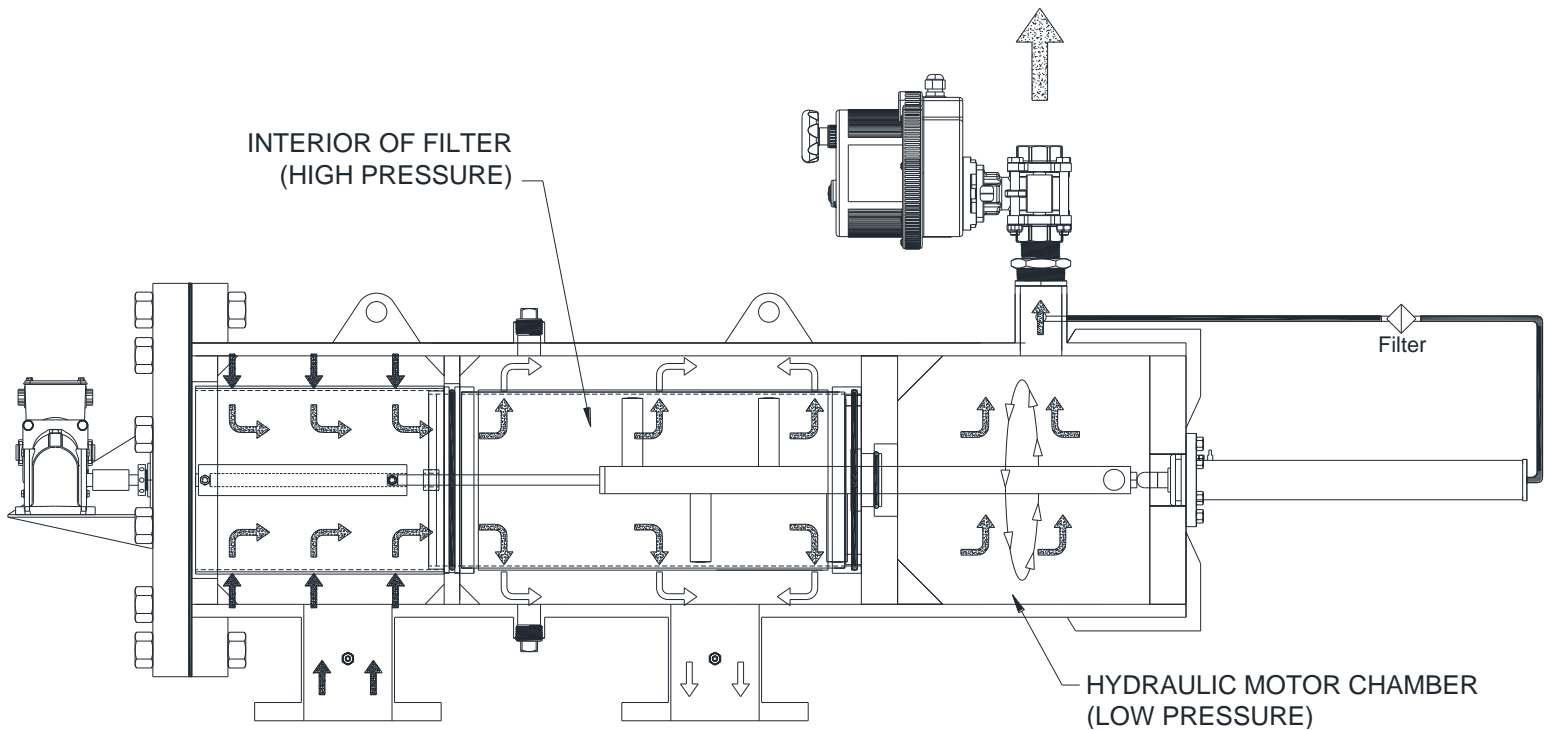

Figure 6: LP180-FRP Series Filter – Normal Operation

This drop in outlet pressure is monitored by the differential pressure gauge, which at seven PSID (pounds per square inch differential) sends a signal to the controller to initiate a backwash cycle.

## Backwash Cycle

The controller opens the flush valve, which causes a drop in pressure in the hydraulic motor chamber. This creates a low-pressure path inside the particle remover, which acts as a vacuum at the end of the suction nozzles, removing the built-up debris from the inside of the fine screen.



*Figure 7: LP180-FRP Series Filter – Backwash Cycle*

Water flows through the suction nozzles, down the interior of the particle remover, and out the hydraulic motor. The motor rotates the particle remover, enabling each suction nozzle to cover a radial strip of screen. And the pressure difference between the interior of the filter and the hydraulic motor chamber drives the particle remover toward the hydraulic piston.

The piston depressurizes during the backwash cycle, and expels the volume of water from its chamber. This acts as a timer, gradually allowing the particle remover to drive the piston rod into the piston, assuring that the suction nozzles cover the entire surface of the fine screen. When the piston reaches the end of its stroke, the backwash cycle is complete, and the flush valve closes. Pressure inside the hydraulic motor chamber normalizes with the rest of the filter, and the piston pushes the particle remover back to its original position.

After the piston and particle remover move back to their original positions, the filter returns to normal operation. During the entire backwash cycle, the main flow through the filter is never disrupted.



## FLOW & PRESSURE REQUIREMENTS

Forsta LP180-FRP Series filters have a minimum pressure requirement of 15 PSI. This includes any pressure loss incurred during the backwash cycle. Therefore, the pump performance is a crucial component in determining whether the filter will perform correctly.

Pump manufacturers will provide the performance data in the form of a pump curve. This is a graph that plots pressure vs. flow rate. A pump is considered adequate for an application if it can maintain a minimum of 15 PSI while pumping the normal system flow AND the additional flow required during backwash. The additional flow depends on the filter model and what valve is used.

<u>Valve</u>	<u>Flow Rate</u>
1.5"	100 gpm
2"	220 gpm

*Figure 8: LP180-FRP Series Filter – Valve Flow Rates*

## MAINTENANCE & SPARE PARTS

### Startup

When pumping water through the Forsta LP180-FRP Series for the first time or after it has been empty, it is important to follow a correct sequence of valve actuation in order to prevent damage to the filter components.

With both isolation valves closed and the bypass valve open, the correct sequence is:

1. Slowly open the inlet isolation valve letting water flow into the filter. If installed, bleed out the air through a valve on the top of the filter body. Let the entire filter fill with water before moving to the next step.
2. Close the bypass valve.
3. Open the outlet isolation valve.

If it is not an option to close the bypass valve momentarily before opening the outlet valve, then both may be actuated simultaneously.

### Shutdown

To remove the filter from operation, reverse the steps used for startup.

1. Close the outlet valve.
2. Open the bypass valve
3. Close the inlet valve, and slowly open the drain valve on the bottom of the filter housing. There will be residual pressure in the tank still, so use caution when draining.

If it is not an option to close the outlet valve momentarily before opening the bypass, then both may be actuated simultaneously.

## Periodic Maintenance

Every six months, or whenever pumps or water flow is shutdown, it is recommended to open and inspect the filter components. Access to the internal components is through the front cover and service port (N4).

Remove the piston from the back plate and drain the water from the piston chamber. Verify that the piston rod is moving smoothly in and out, and inspect the piston tip for wear.

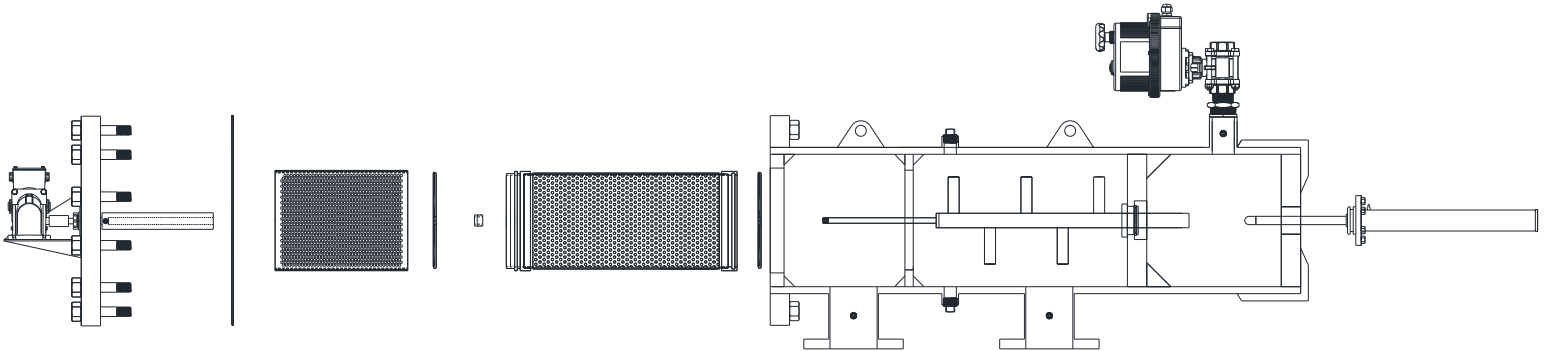

*Figure 9: LP180-FRP Series Filter - Inspection*

Remove the screen and particle remover, using the front cover for access. Both should be extracted in one piece. Separate the two items and inspect both for damage. The screen mesh and bushing should be inspected for wear.

Also inspect the particle remover rod and suction nozzles for wear.

When taking care of the filter, also perform the same periodic maintenance on the piston itself. A step-by-step description of disassembling the piston for maintenance and replacement of parts is displayed on page 12 of the manual.

# Particle Remover

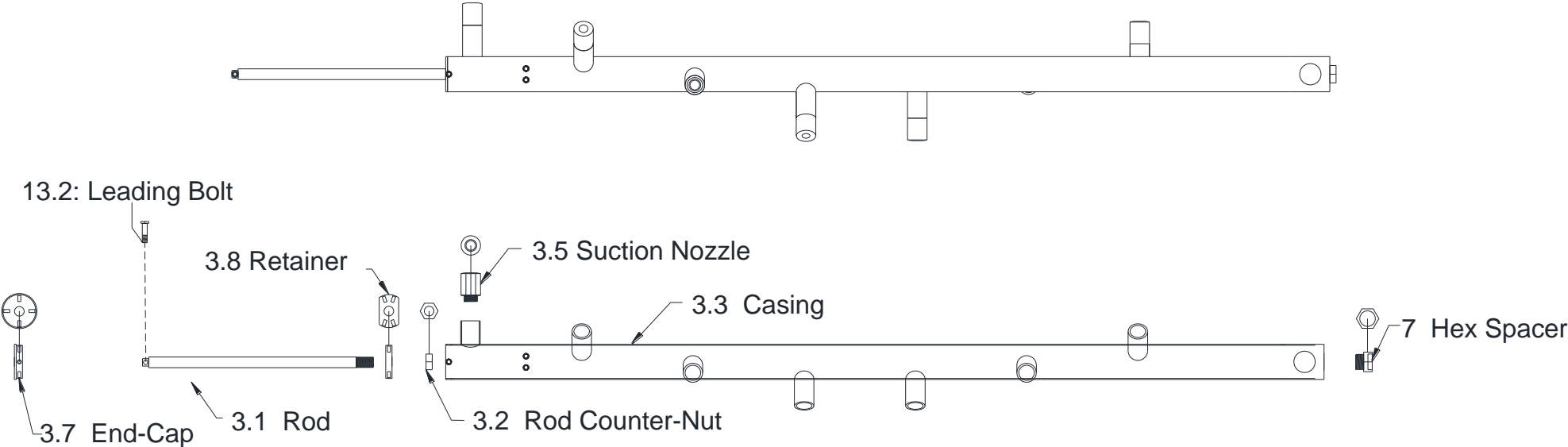

Figure 10: LP180-FRP Series Filter – Particle Remover

## Spare Parts

Spare parts for maintenance for **two** years include:

Part Number	Description	Qty
1.7-180-UHMWPE	Hydraulic Motor Chamber Bushing	1
1.8-180/LP180	Hydraulic Motor Chamber Bushing O-Ring	1
16-1/4-PE	Mini Filter	1
17-Fitting/Tubing	Fitting Tube	1
18-D/P-MW-522P	Pressure Differential Switch	1
3.5-180	Suction Nozzles	*
4-180-SDSS/PE	Stainless Steel Bushing	1
5-180/LP180-FRP	Housing Seal	1
6-180/LP180	Screen O-Ring	2
7-180-SDSS-VES	Stainless Steel Spacer	1
8.9-180-SDSS	Piston Shaft Tip	1
8K-180-FRP	Piston Repair Kit	1
13.1-LP180/LP/180C	DC Motor	1
13.2-LP180-SDSS	Leading Bolt	1
13.3-LP180-DEL	Particle Remover Adaptor	1
13.4-LP180-SDSS	Particle Remover Adaptor Bolt	1
13.6-LP180/LP180C-SDSS	Motor Drive Shaft	1
13.7-LP180/LP180C-SDSS	Compression Packing Housing	1
13.8-LP180/LP180C	Compressing Packing Rope	1
13.9S	DC Motor Drive	1

Spare parts for maintenance for **five** years include:

Part Name	Qty
Plate bushing (1.7)	2
Plate bushing o- ring (1.8)	2
Fine Screen (2)	1
Particle Remover (3)	1
Particle Remover rod (3.1)	1
Suction Nozzles (3.5)	2 Sets
Bushing (4)	2
Cover Seal (5)	2
Screen O-rings (6)	4
Hex Spacer (7)	2
Hydraulic piston (8)	1
Shaft tip (8.9)	2
Piston Seal Kit (8K)	2
Valve (12)	1
Mini-Filter (16)	2
Differential Pressure Gauge (18)	2
Tubing & fitting	2

Figure 11: LP180-FRP Series Filter – 2- and 5-Year Parts Maintenance

## Hydraulic Piston

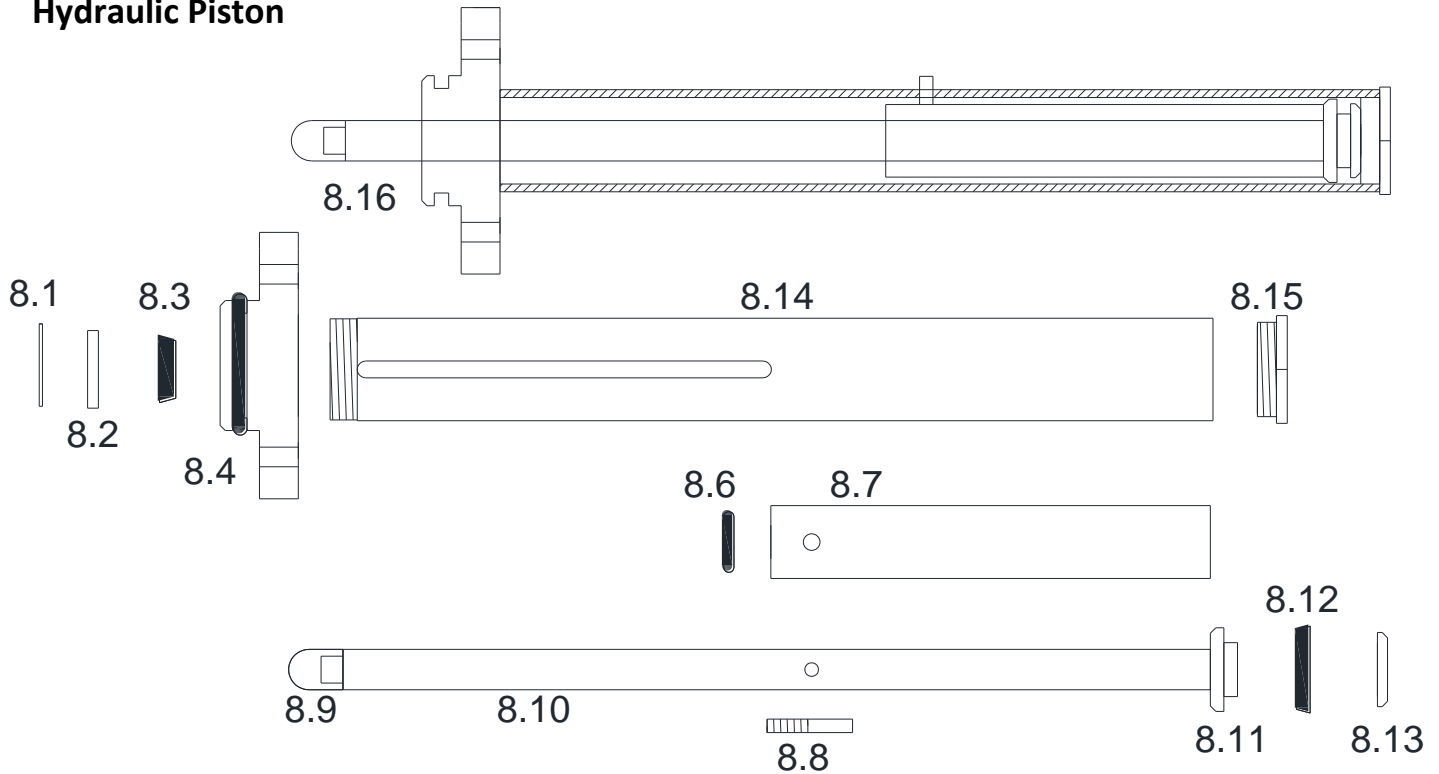

ITEM	PART NUMBER
Hydraulic Piston	8
Snap Ring	8.1
Head Ring	8.2
Shaft U-Cup	8.3
Head O-Ring	8.4
Shaft O-Ring	8.6
Pin Holder	8.7
Position Pin	8.8
Shaft Tip	8.9
Shaft	8.10
U-Cup Holder	8.11
Casing U-Cup	8.12
U-Cup Holder Cap	8.13
Casing	8.14
Casing Cap	8.15
Piston Head	8.16

Figure 12: LP180-FRP Series Filter – Part List – Hydraulic Piston

## Piston Seal Replacement Guide

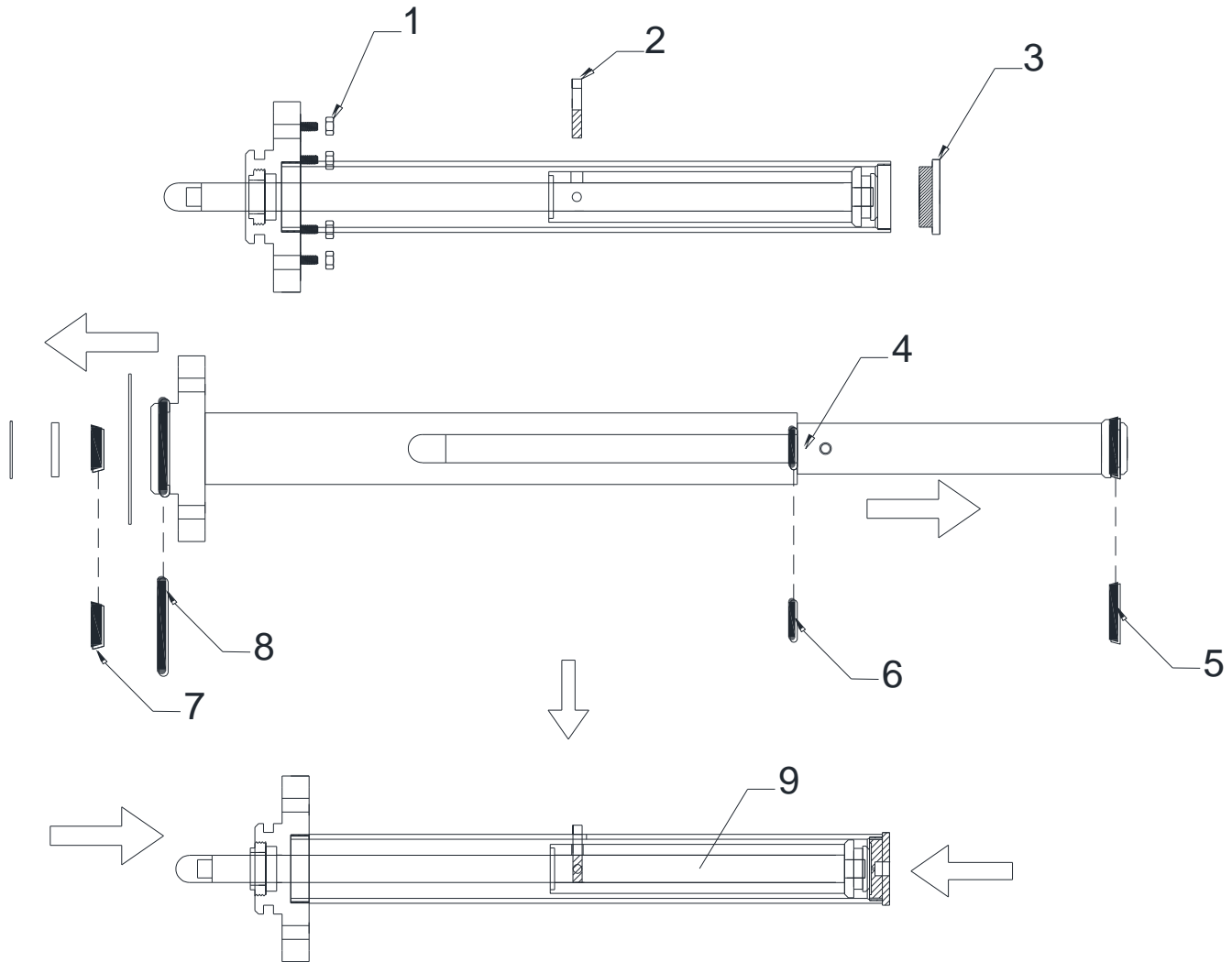

1. Drain filter body, remove the hex nuts, remove the piston from the filter
2. Unscrew the piston pin and pull out
3. Unscrew the casing cap (8.15) and remove
4. Remove internal piston assembly which consists of parts 8.6 - 8.12
5. Replace casing U-cup (8.12)
6. Replace shaft O-ring (8.6)
7. Replace shaft U-cup (8.3)
8. Replace head O-ring (8.4)
9. Before reassembling, lubricate internal surfaces using silicone grease
10. Ensure everything is clean and lubricated before reversing the steps to assemble

Figure 13: LP180-FRP Series Filter – Piston Seal Replacement

# Troubleshooting Guide

## 1. PRESSURE / 2. BACKWASH PRESSURE

During normal operation, record the pressure reading at inlet connection K1. If the pressure is below 20 psi, this is your problem.

During backwash, record the pressure reading at inlet connection K1 (flush valve open). If the pressure is below 20 psi, this is your problem.

### Solution

Increase system pressure by:

- Choking the outlet of the filter.
- Ramping up pump.
- Replacing pressure gauge if it is defective.

## 3. FLUSH PORT

Record the pressure reading at flush outlet connection K3 during backwash.

If no pressure gauge is installed on K3, add a tee ("T") connection to install gauge.

If the pressure does not read 0 psi during backwash, this is your problem.

### Solution

- Re-pipe the flush line to prevent back-pressure. Remove elbows, elevation gain, and oversize the pipe.
- Flush directly to a nearby tank.
- Increase flush valve size.

## 4. MINI FILTER

Inspect mini-filter located on the piston tubing line. If the mini-filter is clogged, this is your problem.

### Solution

- Wash the mini-filter.

## 5. HYDRAULIC PISTON

Inspect the hydraulic piston (8). Verify that the rod can smoothly move back and forth, and that the pin moves the entire length of the slot.

### Solution

- Open the brass hex caps and inspect the rubber seals for wear. They may need to be replaced.
- Check that the hex cap (8.15) has a small hole through it to allow water to flow out of the piston. If this orifice is obstructed, remove debris.

## 6. PARTICLE REMOVER

Inspect the internal components for smooth operation. If the particle remover is jammed, this is your problem.

### Solution

- Bypass the filter and relieve pressure. Open the connection clamp, and remove the top section of the filter. The particle remover should rotate freely inside the center of the plate.
- Remove the plate and inspect the particle remover. The rod should be inserted into the bushing near the inlet of the filter. There should be clearance between the suction nozzles and the screen.
- Check for any severe damage or wear on any of the components.

## LP180FRP SERIES FILTER - NORMAL OPERATION

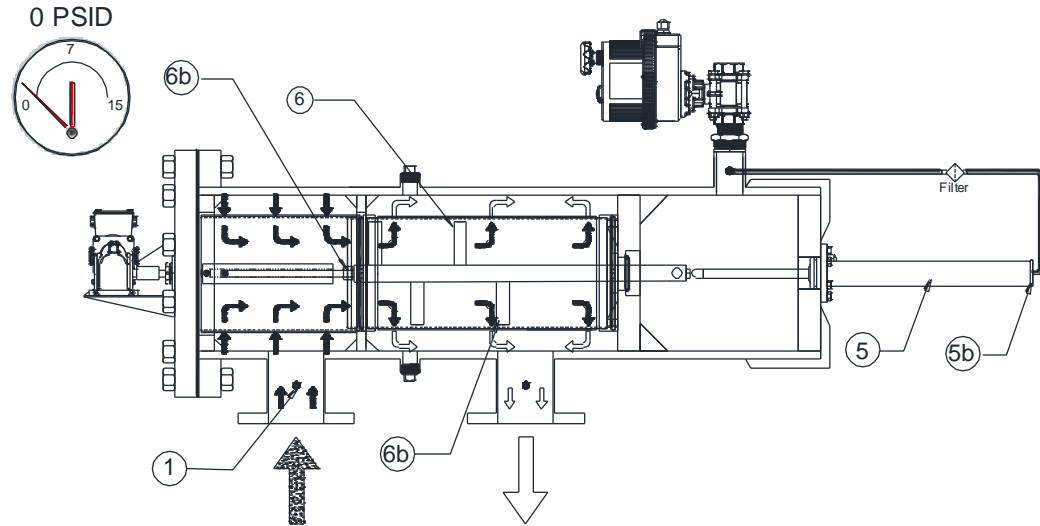

## LP180FRP SERIES FILTER - BACKWASH CYCLE

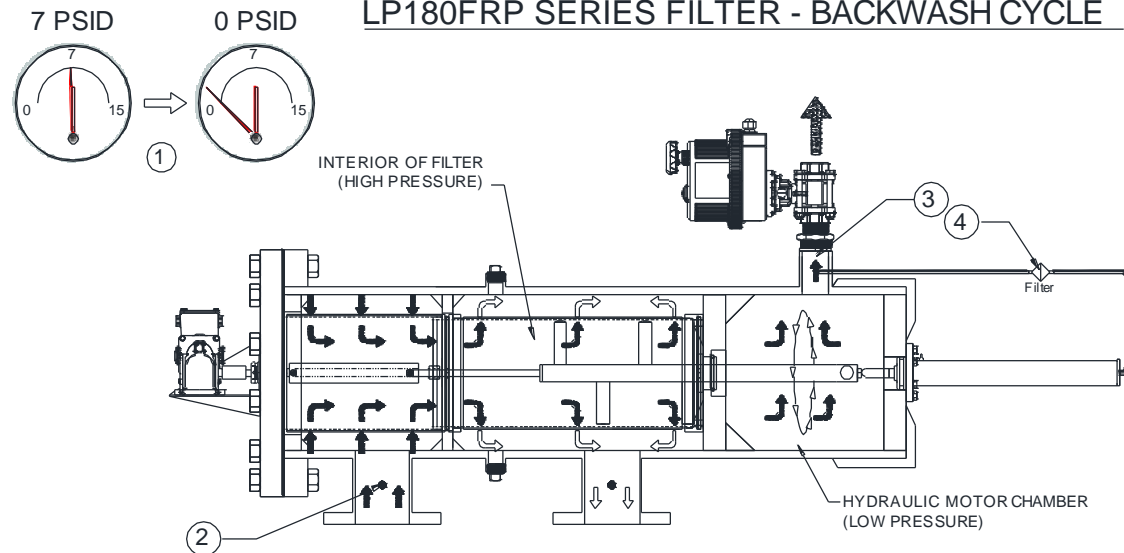
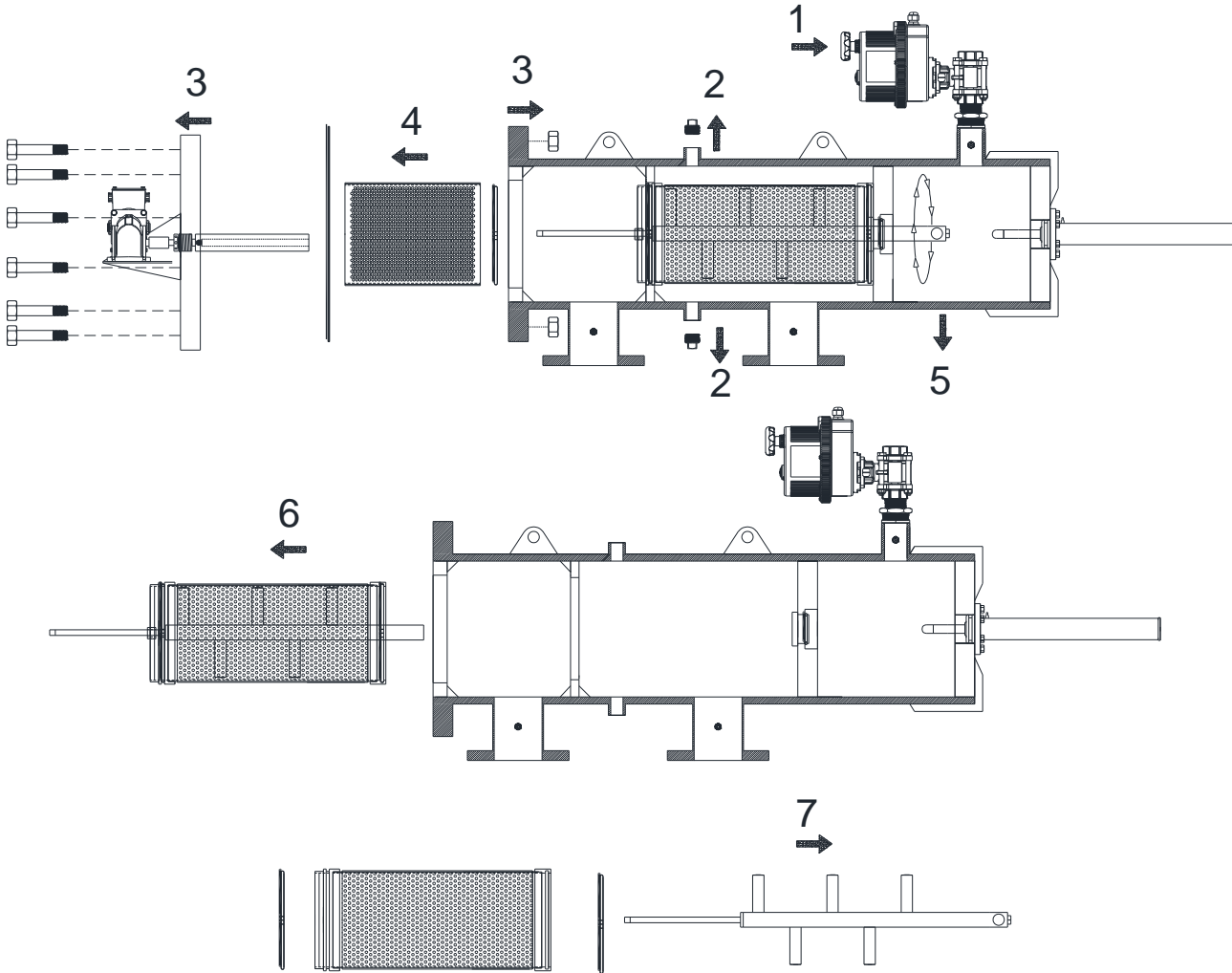

Figure 14: LP180-FRP Series Filter – Troubleshooting

## Screen Removal Instructions



1. Relieve any static pressure in the filter body by running a backwash cycle and turning off the system once the gauge reads 0 psi.
2. Once at 0psi, open the Couplings (N5). Fully relieve the filter from all pressure and drain all the water
3. Remove the bolts and nuts holding the front plate and the motor attached together, then remove the front plate with the Housing Seal.
4. Remove the coarse screen from inside the filter body and set aside for observation later
5. Remove the sprinkler in the hydraulic motor chamber through the service port. The sprinkler is held on with a left handed thread
6. Remove the fine screen and particle remover all together by pulling on the screen bar
7. Separate the fine screen and particle remover by sliding the particle remover out of the screen

Figure 15: LP180-FRP Series Filter – Screen Removal



## Screen Installation Instructions

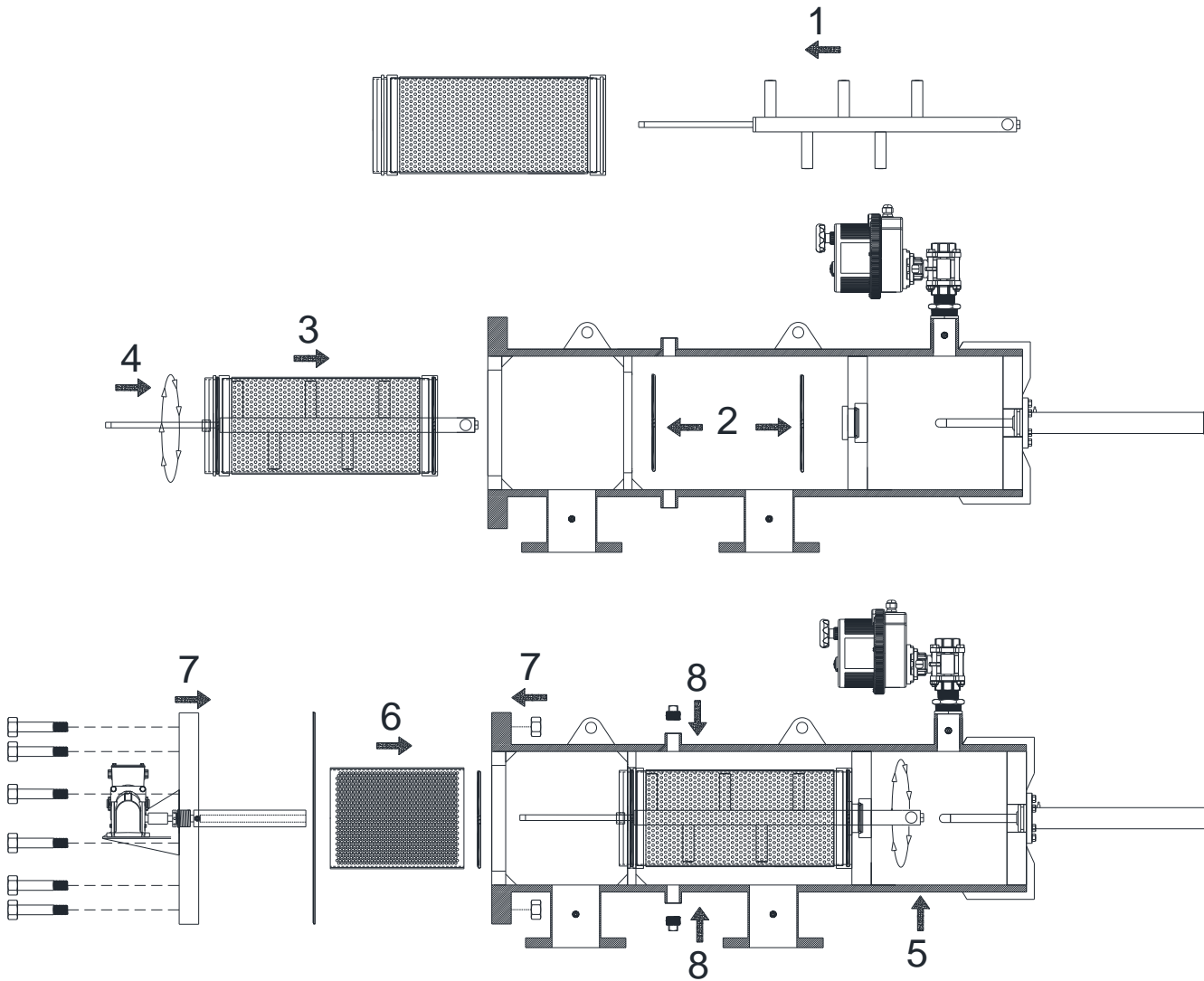

1. Insert the particle remover into the screen, guiding the rod into the screen bushing.
2. Lubricate the screen O-rings with NSF 61 approved silicone grease before installation .
3. Lift the fine screen with the particle remover as one unit and insert into the filter body. Guide the particle remover through the internal bushing at the opposite end of the filter body. Lift the screen as you guide it, end of the filter body
4. Hold the screen by the screen handles and rotate the screen 180 degrees as you push the screen into the body, allowing the screen to center itself. Once aligned, push the screen until it seals
5. Install the sprinkler in the hydraulic motor chamber and rotate the particle remover by hand ensuring unobstructed rotation
6. Install the coarse screen into the filter body.
7. Verify the cover seal is properly installed on the cover O-ring groove and secure the cover and motor system with the set of bolts and nuts. Follow a star pattern of fastening nuts
8. Reinstall the unplugged service ports, tighten down, verify they are all secure, and bring the filter back online. Inspect for any leaks.

Figure 16: LP180-FRP Series Filter – Screen Installation

# INSTALLATION & WIRING

## LP180-FRP Series Filters Wiring

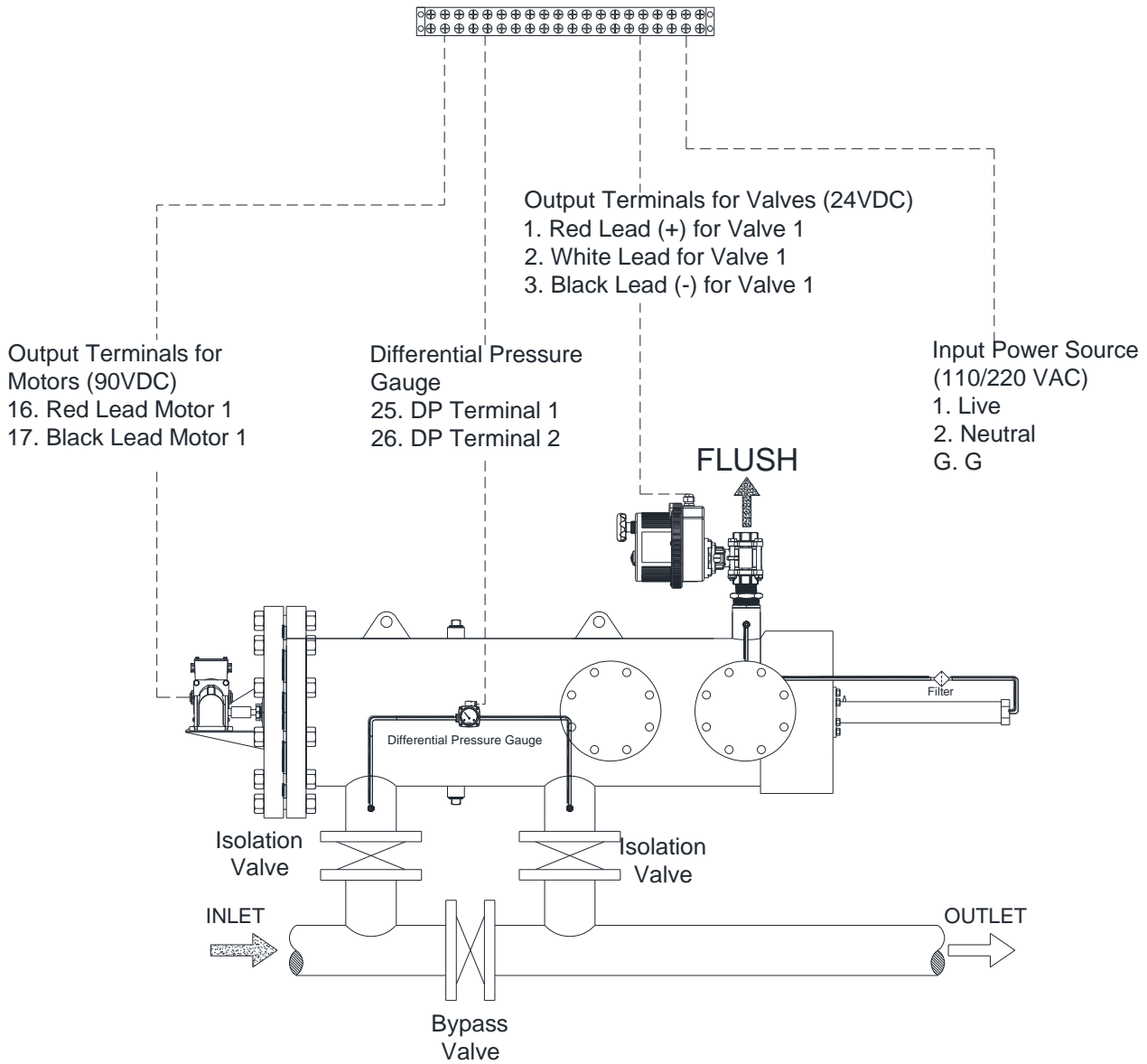
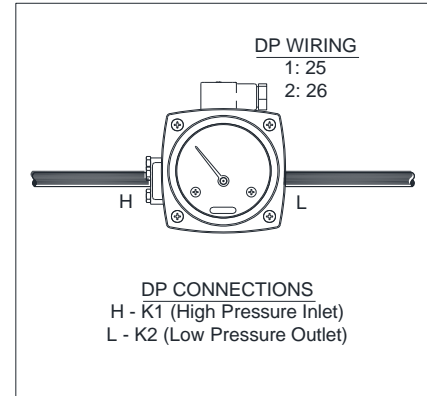
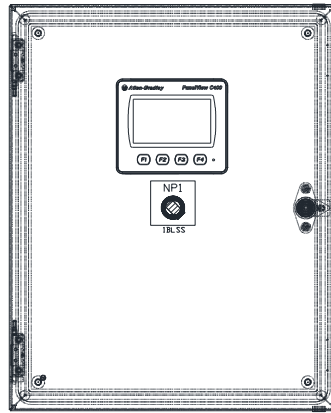

Figure 17: LP180-FRP Series Filter – EC-2 Wiring

## 2xLP180-FRP Series Filters in Parallel

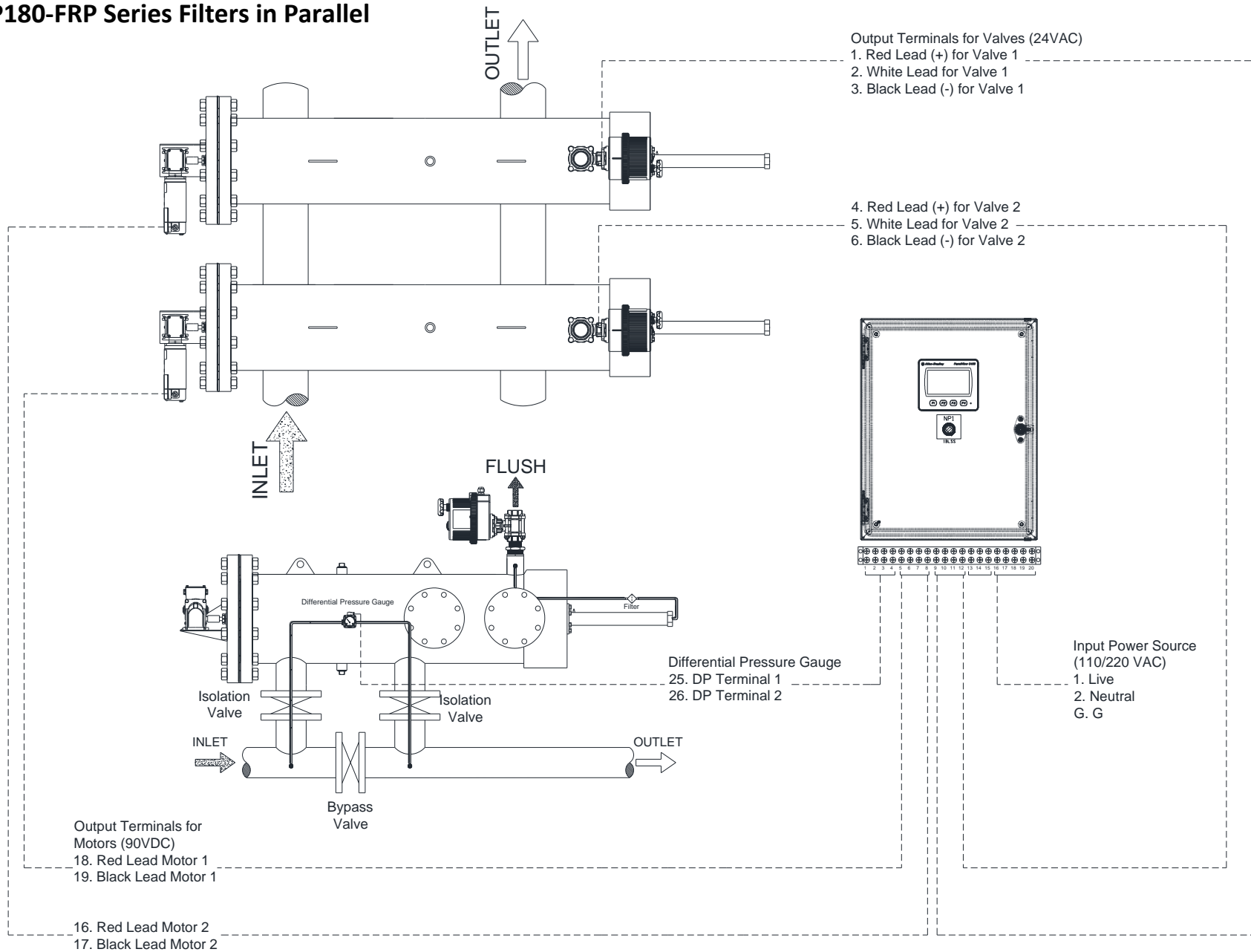

Figure 18: LP180-FRP Series Filter – 2xLP180-FRP in Parallel

## **WARRANTY**

Forsta Filters guarantees all self-cleaning water filters, components, and accessories free of defects for one year from the date of installation, or 18 months from the date of original shipment. Forsta will replace any part found defective during the warranty period, provided the equipment in question was handled, installed, and operated in accordance with the operation and maintenance manual and sound engineering practices. Forsta Filters assumes no liability for incidental or consequential damage resulting from the use of its products, services, or data. Liability is limited to replacement or repair of products provided by Forsta Filters, and no agent or sales representative has authority to extend the warranty period without the express written consent of Forsta Filters, Inc. Shipping charges for returned equipment will be at the expense of the purchaser, and all returned equipment must be sent to Forsta Filters