

180 SERIES OPERATION AND MAINTENANCE MANUAL



TABLE OF CONTENTS

FILTER BASICS	1
<i>Figure 1: 180 Series Filter – General Layout</i>	1
<i>Figure 2: 180 Series Filter – Assembled View</i>	1
<i>Figure 3: 180 Series Filter – Exploded View</i>	1
QUICK START GUIDE	2
<i>Figure 4: 180 Series Filter – Quick Start Guide</i>	2
INSTALLATION REQUIREMENTS	3
<i>Figure 5: 180 Series Filter – Installment Layout</i>	3
Couplings	3
Flush Line.....	3
Hydraulic Connections.....	4
Hydraulic Piston.....	4
FILTER PERFORMANCE	4
Normal Operation.....	4
<i>Figure 6: 180 Series Filter – Normal Operation</i>	4
Backwash Cycle.....	5
<i>Figure 7: 180 Series Filter – Backwash Cycle</i>	5
FLOW & PRESSURE REQUIREMENTS	6
<i>Figure 8: 180 Series Filter – Valve Flow Rates</i>	6
MAINTENANCE & SPARE PARTS	6
Startup.....	6
Shutdown.....	6
Periodic Maintenance	7
<i>Figure 9: 180 Series Filter – Inspection</i>	7
Particle Remover	8
<i>Figure 10: 180 Series Filter – Particle Remover</i>	8
Spare Parts.....	9
<i>Figure 11: 180 Series Filter – 2- 5-year Parts Maintenance</i>	9
Hydraulic Piston.....	10
<i>Figure 12: 180 Series Filter – Hydraulic Piston</i>	10
Piston Seal Replacement Instructions.....	11
<i>Figure 13: 180 Series Filter – Piston Seal Replacement</i>	11
Troubleshooting Guide.....	12
<i>Figure 14: 180 Series Filter – Trouble Shooting</i>	12
Screen Removal/Installation Instructions	13
<i>Figure 15: 180 Series Filter – Screen Removal</i>	13
<i>Figure 16: 180 Series Filter – Screen Installation</i>	14
INSTALLATION & WIRING	15
180 Series Filters Wiring.....	15
<i>Figure 17: 180 Series Filter – EC-2 Wiring</i>	15
2x180 Series Filters in Parallel.....	16
<i>Figure 18: 180 Series Filter – 2x180 in Parallel</i>	16
WARRANTY	17

FILTER BASICS

The Forsta 180 Series is a self-cleaning screen water filter. The major components include the Filter Housing (1), Coarse Screen pre-filter (11), Fine Screen filter element (2), Particle Remover (3), Hydraulic Piston (8), and Backwash Valve (12).

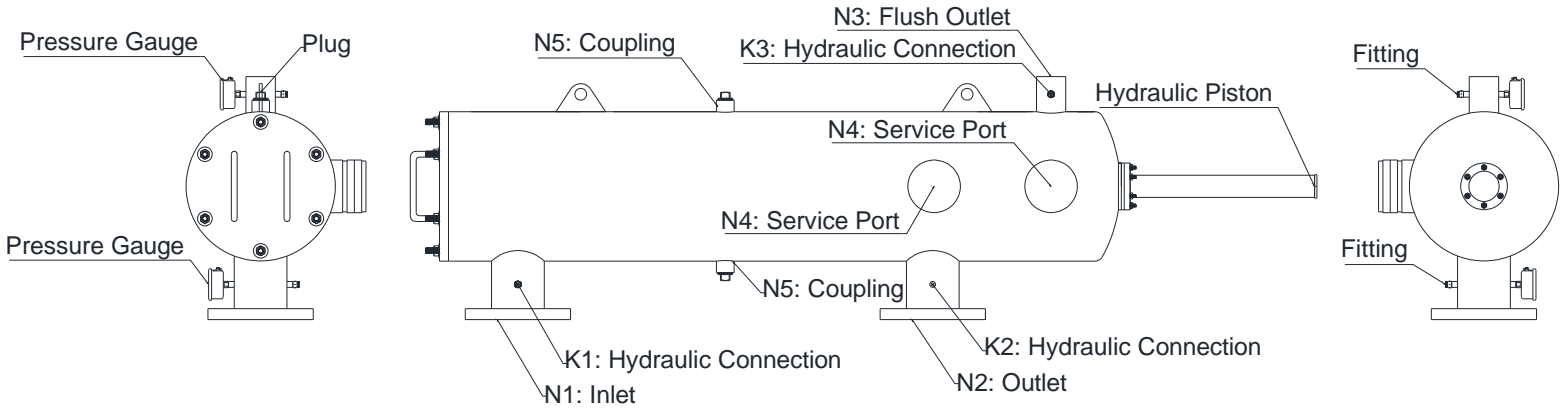

Figure 1: 180 Series Filter – General Layout

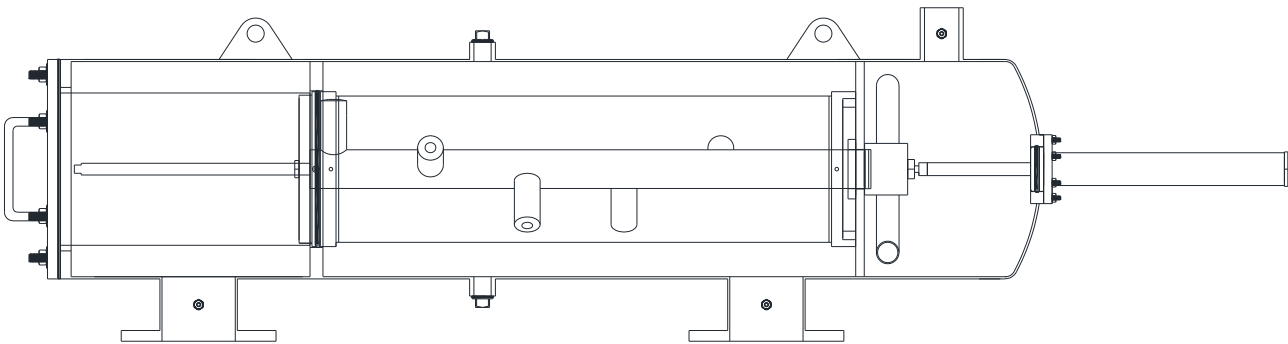

Figure 2: 180 Series Filter – Assembled View

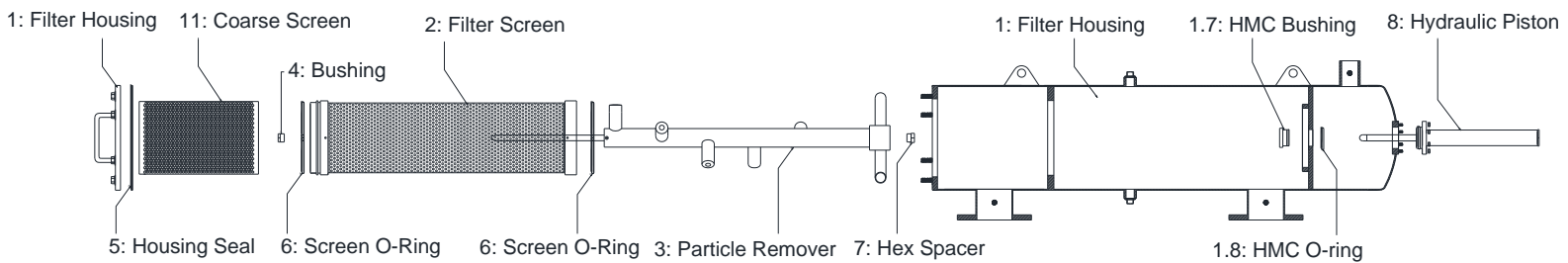

Figure 3: 180 Series Filter - Exploded View

QUICKSTART GUIDE

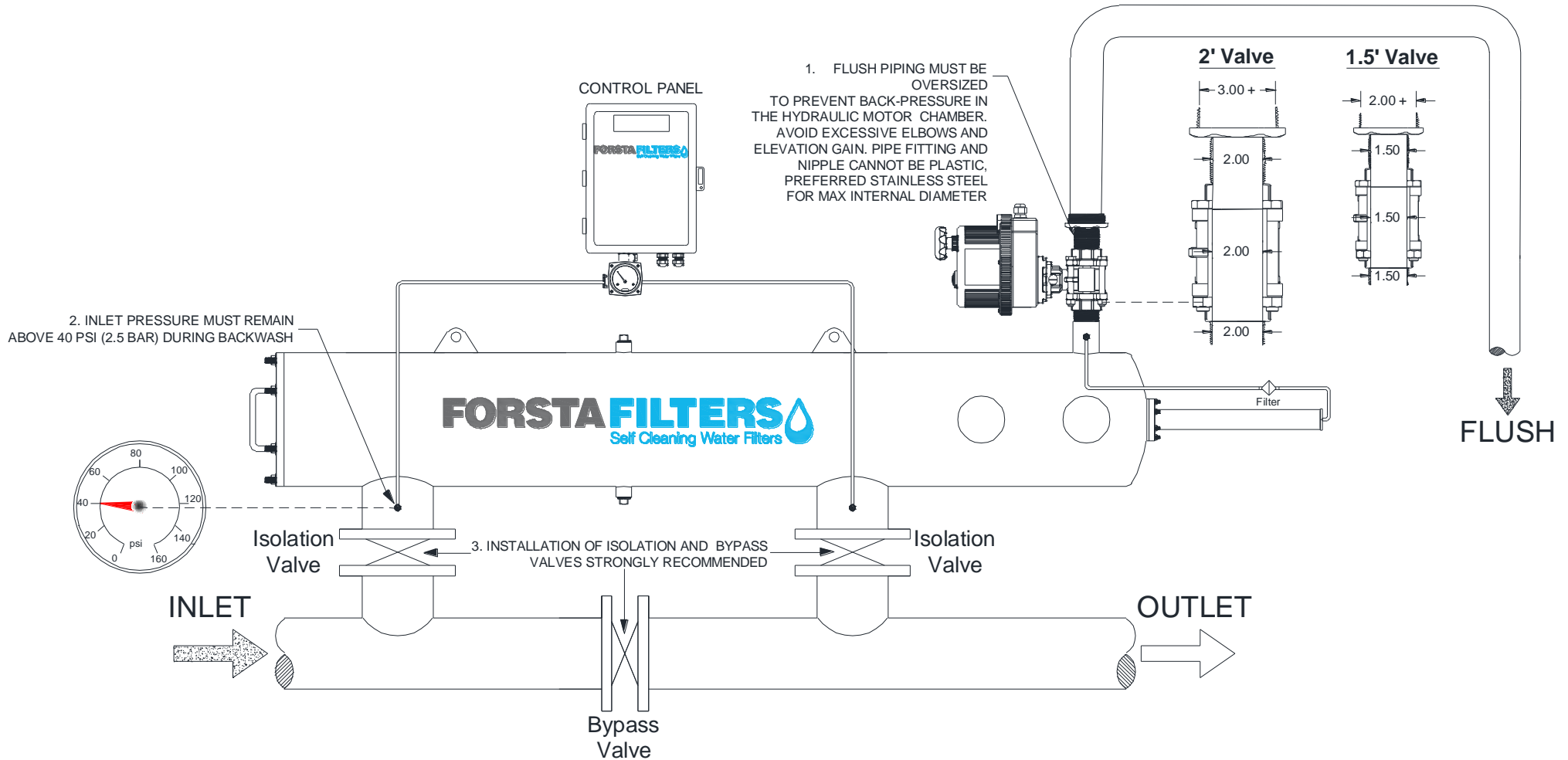

Figure 4: 180 Series Filter – Quick Start Guide

INSTALLATION REQUIREMENTS

180 Series filters may be mounted directly on the inlet (N1) and outlet (N2) flanges, and positioned in any orientation. As shown below in figure 4, isolation valves should be installed at the inlet and outlet, and a bypass valve should be installed between the flanges. This will allow the filter to be taken offline without disruption to water flow.

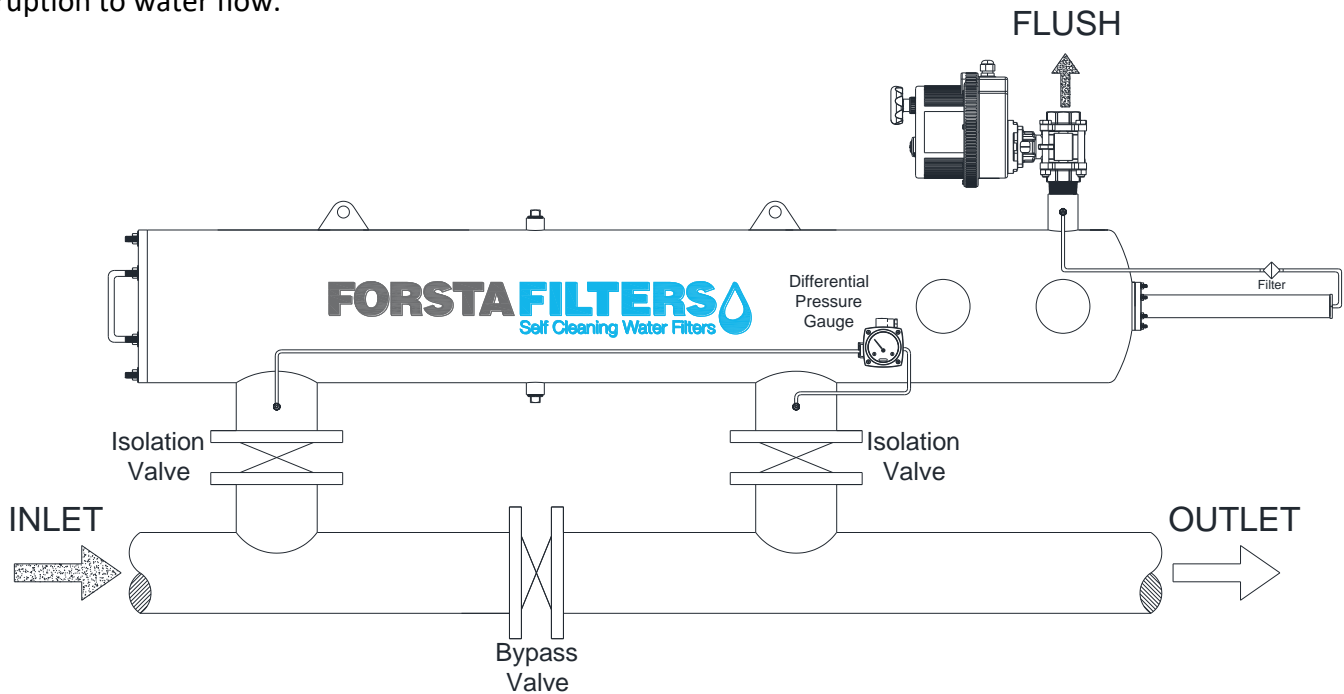

Figure 5: 180 Series Filter – Installment Layout

There should be adequate clearance around the filter to allow for easy maintenance access, including a minimum of 24" from the back (piston side). The minimum clearance on the front (cover) depends on the model. There must be enough room to remove the coarse screen and fine screen periodically.

Couplings

It is recommended to use the 1" threaded half couplings (N5) for air bleed-off during startup, and draining when taking the filter offline. Valves may be installed at both locations, otherwise the couplings remain plugged.

Flush Line

The piping for the flush valve must have no backpressure. It is strongly recommended to use oversized piping to accommodate this requirement. For example, if the 180 Series filter uses a 2" valve, the recommended pipe is a minimum of 3". For a 1" valve, 1.5" or 2" pipe must be used.

To minimize backpressure on the flush line, it is also important to avoid elevation gain in the flush line. Even small elevation gains will reduce the filter's ability to perform an effective backwash cycle. If flush water must be transported to higher elevation, it is recommended to pipe the flush line to a storage tank first, and then pump it out to higher elevation. Additionally, avoid any sharp bends and shifts of direction to allow a smooth flow of water during backwash.

Hydraulic Connection

Each flanged connection nozzle (N1 & N2) on the 180 Series filter has two ¼" threaded couplings. One may be used to install a pressure gauge or other sensor equipment. The other ¼" coupling will be used to connect hydraulic tubing from the differential pressure switch to the filter. The high-pressure line is fitted to the inlet, and low pressure fitted to the outlet.

Hydraulic Piston

The piston (8) is mounted on the domed end of the filter. ¼" tubing must be installed from the fitting located on the back of the piston to the hydraulic connection (K3) on the flush outlet (N3). A filter is installed on the hydraulic tubing to protect the piston.

FILTER PERFORMANCE

Normal Operation

During normal operation of the filter, dirty water enters through the inlet and passes through the coarse screen. Any abnormally large debris is caught here and prevented from possibly damaging the fine screen or particle remover.

Water then travels down the center of the filter and is strained across the fine screen. As water passes from inside the screen to outside, suspended particles are trapped on the fine screen and continue to buildup, eventually creating a drop in pressure at the outlet of the filter.

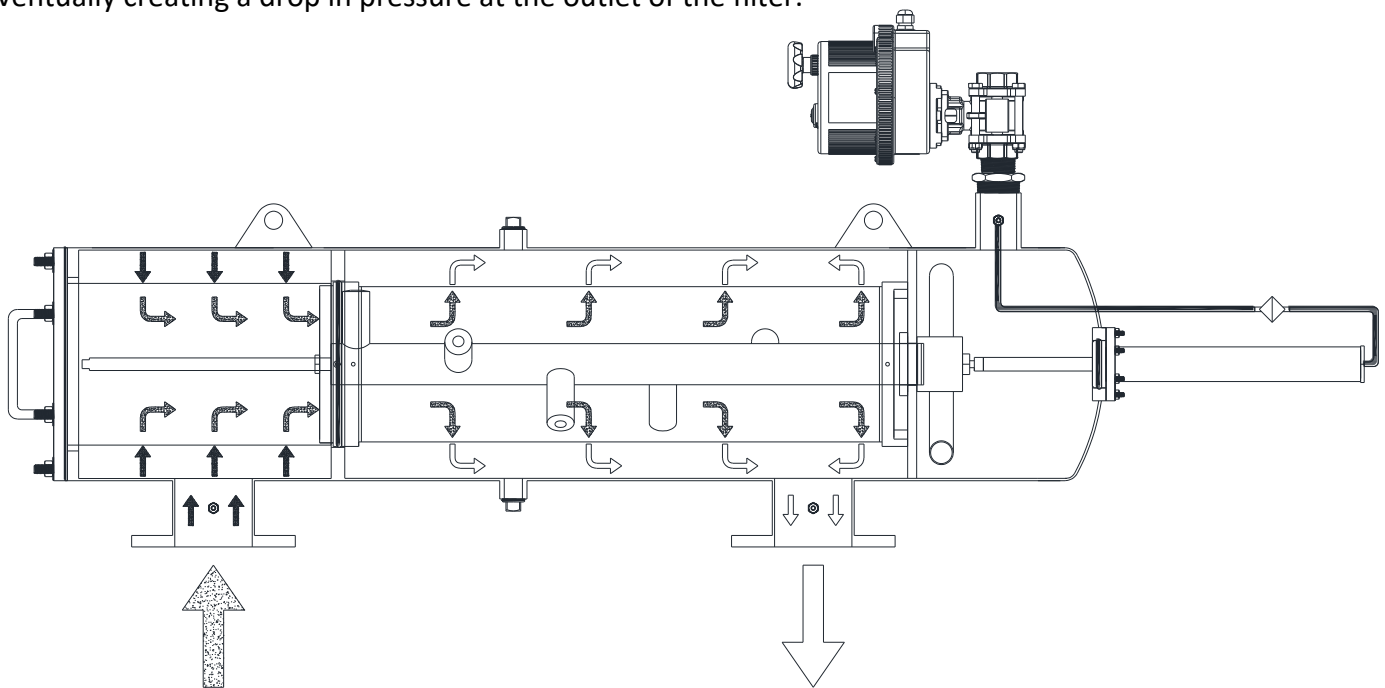

Figure 6: 180 Series Filter – Normal Operation

This drop in outlet pressure is monitored by the differential pressure gauge, which at seven PSID (pounds per square inch differential) sends a signal to the controller to initiate a backwash cycle.

Backwash Cycle

The controller opens the flush valve, which causes a drop in pressure in the hydraulic motor chamber. This creates a low-pressure path inside the particle remover, which acts as a vacuum at the end of the suction nozzles, removing the built-up debris from the inside of the fine screen.

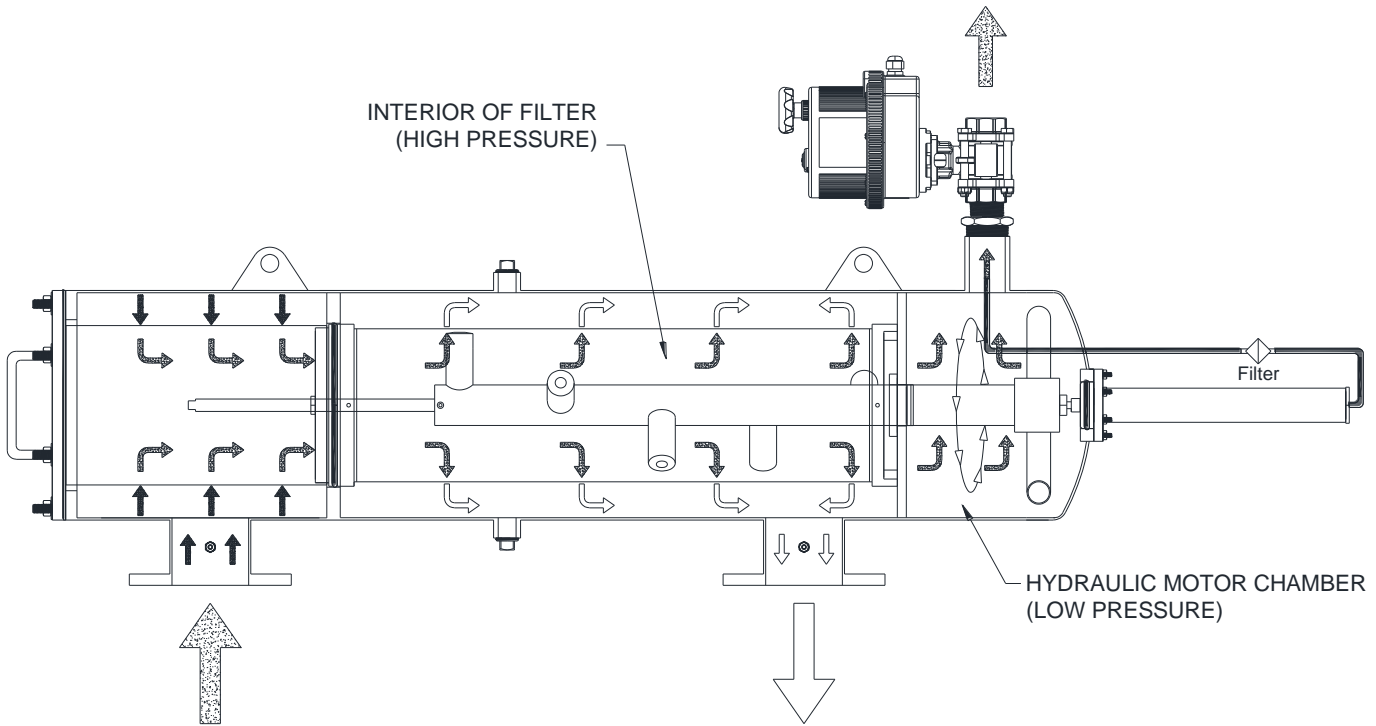

Figure 7: 180 Series Filter – Backwash Cycle

Water flows through the suction nozzles, down the interior of the particle remover, and out the hydraulic motor. The rapid flow of water through the hydraulic motor forces the entire particle remover to rotate, enabling each suction nozzle to cover a radial strip of screen. And the pressure difference between the interior of the filter and the hydraulic motor chamber drives the particle remover toward the hydraulic piston.

The piston depressurizes during the backwash cycle, and expels the volume of water from its chamber. This acts as a timer, gradually allowing the particle remover to drive the piston rod into the piston, assuring that the suction nozzles cover the entire surface of the fine screen. When the piston reaches the end of its stroke, the backwash cycle is complete, and the flush valve closes. Pressure inside the hydraulic motor chamber normalizes with the rest of the filter, and the piston pushes the particle remover back to its original position.

After the piston and particle remover move back to their original positions, the filter returns to normal operation. During the entire backwash cycle, the main flow through the filter is never disrupted.

FLOW & PRESSURE REQUIREMENTS

Forsta 180 Series filters have a minimum pressure requirement of 40 PSI. This includes any pressure loss incurred during the backwash cycle. Therefore, the pump performance is a crucial component in determining whether the filter will perform correctly.

Pump manufacturers will provide the performance data in the form of a pump curve. This is a graph that plots pressure vs. flow rate. A pump is considered adequate for an application if it can maintain a minimum of 40 PSI while pumping the normal system flow AND the additional flow required during backwash. The additional flow depends on the filter model and what valve is used.

<u>Valve</u>	<u>Flow Rate</u>
1.5"	100 gpm
2"	220 gpm

Figure 8: 180 Series Filter – Valve Flow Rates

MAINTENANCE & SPARE PARTS

Startup

When pumping water through the Forsta 180 Series for the first time or after it has been empty, it is important to follow a correct sequence of valve actuation in order to prevent damage to the filter components.

With both isolation valves closed and the bypass valve open, the correct sequence is:

1. Slowly open the inlet isolation valve letting water flow into the filter. If installed, bleed out the air through a valve on the top of the filter body. Let the entire filter fill with water before moving to the next step.
2. Close the bypass valve.
3. Open the outlet isolation valve.

If it is not an option to close the bypass valve momentarily before opening the outlet valve, then both may be actuated simultaneously.

Shutdown

To remove the filter from operation, reverse the steps used for startup.

1. Close the outlet valve.
2. Open the bypass valve
3. Close the inlet valve, and slowly open the drain valve on the bottom of the filter housing. There will be residual pressure in the tank still, so use caution when draining.

If it is not an option to close the outlet valve momentarily before opening the bypass, then both may be actuated simultaneously.

Periodic Maintenance

Once a year, or whenever pumps or water flow is shutdown, it is recommended to open and inspect the filter components. Access to the internal components is through the front cover and service port (N4).

Remove the piston from the back plate and drain the water from the piston chamber. Verify that the piston rod is moving smoothly in and out, and inspect the piston tip for wear.

3

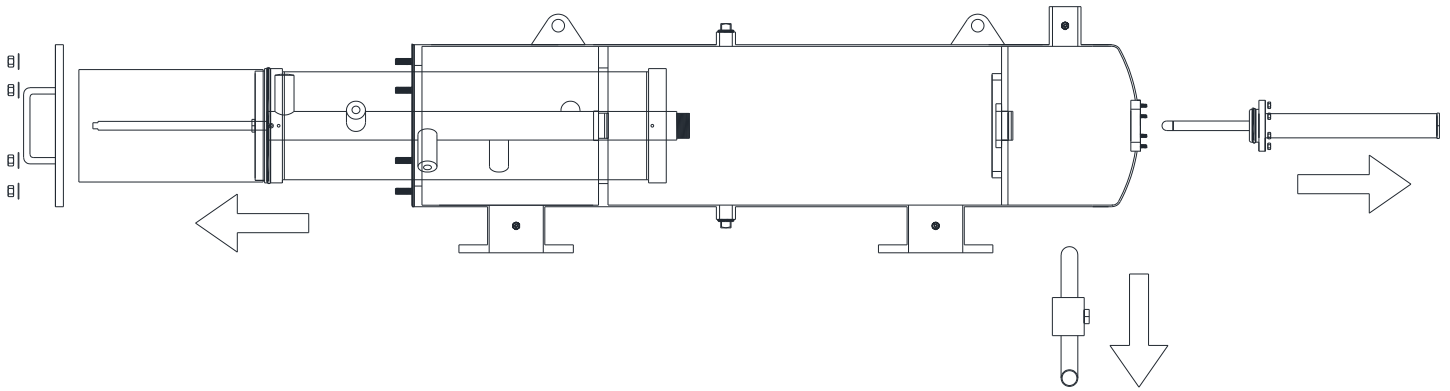

Figure 9: 180 Series Filter - Inspection

Remove the hydraulic motor from the rest of the particle remover by accessing it through the service port. It has a left-hand thread, so it must be turned to the right to loosen it.

Remove the screen and particle remover, using the front cover for access. Both should be extracted in one piece. Separate the two items and inspect both for damage. The screen mesh and bushing should be inspected for wear.

Also inspect the particle remover rod and suction nozzles for wear.

When taking care of the filter, also perform the same periodic maintenance on the piston itself. A step-by-step description of disassembling the piston for maintenance and replacement of parts is displayed on page 12 of the manual. Furthermore, an animated video of the individual parts being assembled and disassembled will be provided in the “180 series” link on our website

Particle Remover

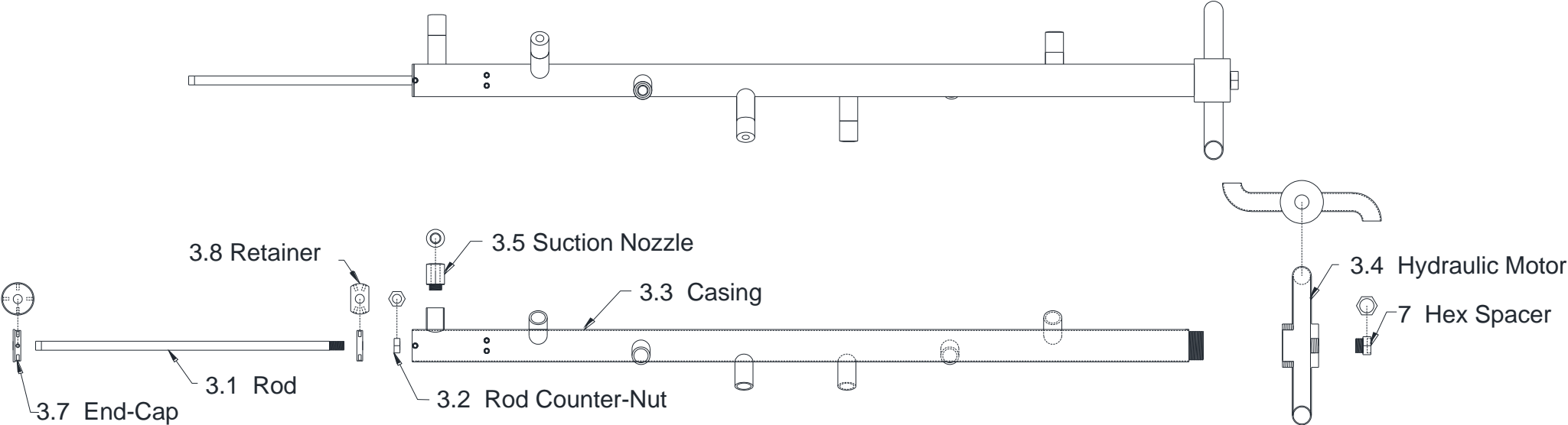

Figure 10: 180 Series Filter – Particle Remover

Spare Parts

Spare parts for maintenance
for **two** years include:

Part Number	Description	Qty
1.7-180-UHMWPE	Hydraulic Motor Chamber Bushing	1
1.8-180/LP180	Hydraulic Motor Chamber Bushing O-Ring	1
16-1/4	Mini Filter	1
17-Fitting/Tubing	Fitting Tube	1
18-D/P-MW-522A	Pressure Differential Switch	1
3.5-180	Suction Nozzles	4-7
4-180-316L/PE	Stainless Steel Bushing	1
5-180/LP180	Housing Seal	1
6-180/LP180	Screen O-Ring	2
7-180-316L-VES	Stainless Steel Spacer	1
8.9-180-316	Piston Shaft Tip	1
8K-180	Piston Repair Kit	1

Spare parts for maintenance
for **five** years include:

Part Name	Qty
Plate bushing (1.7)	2
Plate bushing o- ring (1.8)	2
Fine Screen (2)	1
Particle Remover (3)	1
Particle Remover rod (3.1)	1
Suction Nozzles (3.5)	2 Sets
Bushing (4)	2
Cover Seal (5)	2
Screen O-rings (6)	4
Hex Spacer (7)	2
Hydraulic piston (8)	1
Shaft tip (8.9)	2
Piston Seal Kit (8K)	2
Valve (12)	1
Mini-Filter (16)	2
Differential Pressure Gauge (18)	2
Tubing & fitting	2

Figure 11: 180 Series Filter – 2- and 5-Year Parts Maintenance

Hydraulic Piston

8

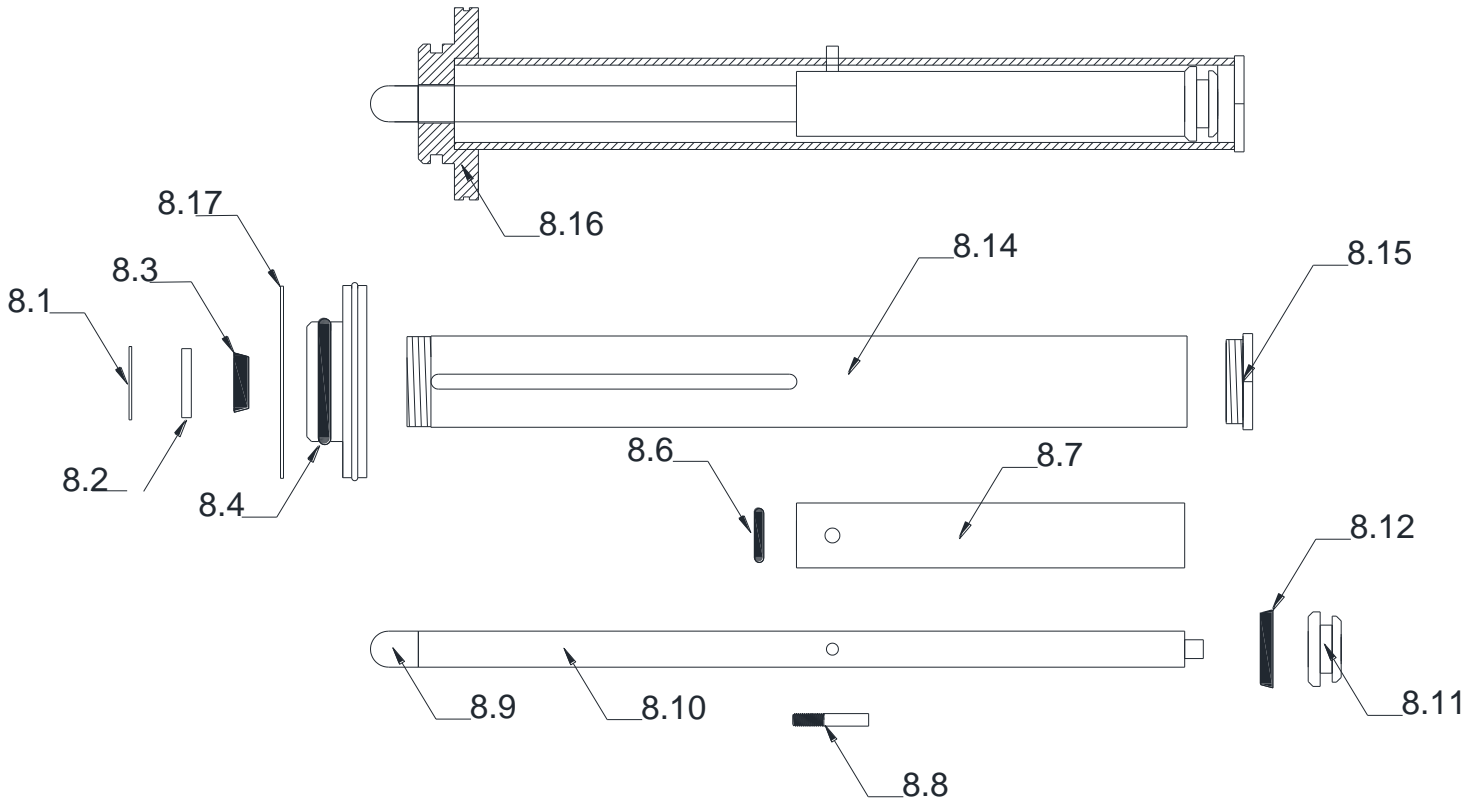

PART NAME	PART NUMBER
Hydraulic Piston	8
Snap Ring	8.1
Head Ring	8.2
Shaft U-Cup	8.3
Head O-Ring	8.4
Shaft O-Ring	8.6
Pin Holder	8.7
Position Pin	8.8
Shaft Tip	8.9
Piston Shaft	8.10
U-Cup Holder	8.11
Casing U-Cup	8.12
Casing	8.14
Casing Cap	8.15
Piston Head	8.16
Head Gasket	8.17

Figure 12: 180 Series Filter – Part List – Hydraulic Piston

Piston Seal Replacement Guide

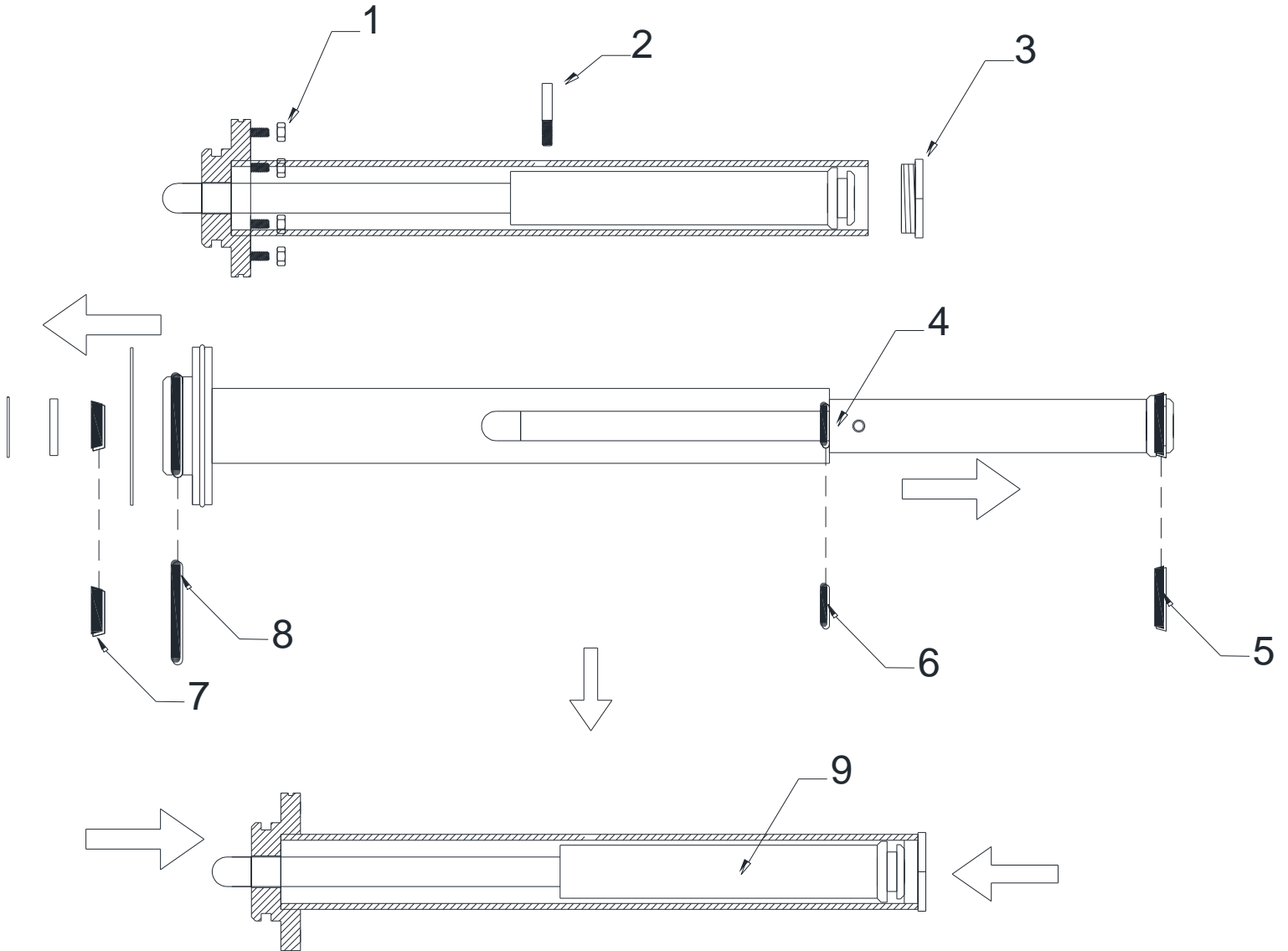

1. Drain filter body, remove the hex nuts, remove the piston from the filter
2. Unscrew the piston pin and pull out
3. Unscrew the casing cap (8.15) and remove
4. Remove internal piston assembly which consists of parts 8.6 - 8.12
5. Replace casing U-cup (8.12)
6. Replace shaft O-ring (8.6)
7. Replace shaft U-cup (8.3)
8. Replace head O-ring (8.4)
9. Before reassembling, lubricate internal surfaces using silicone grease
10. Ensure everything is clean and lubricated before reversing the steps to assemble

Figure 13: 180 Series Filter – Piston Seal Replacement

Troubleshooting Guide

1. PRESSURE / 2. BACKWASH PRESSURE

During normal operation, record the pressure reading at inlet connection K1. If the pressure is below 35psi, this is your problem.

During backwash, record the pressure reading at inlet connection K1 (flush valve open). If the pressure is below 35 psi, this is your problem.

Solution

Increase system pressure by:

- Choking the outlet of the filter.
- Ramping up pump.
- Replacing pressure gauge if it is defective.

3. FLUSH PORT

Record the pressure reading at flush outlet connection K3 during backwash.

If no pressure gauge is installed on K3, add a tee ("T") connection to install gauge.

If the pressure does not read 0 psi during backwash, this is your problem.

Solution

- Re-pipe the flush line to prevent back-pressure. Remove elbows, elevation gain, and oversize the pipe.
- Flush directly to a nearby tank.
- Increase flush valve size.

4. MINI FILTER

Inspect mini-filter located on the piston tubing line. If the mini-filter is clogged, this is your problem.

Solution

- Wash the mini-filter.

5. HYDRAULIC PISTON

Inspect the hydraulic piston (8). Verify that the rod can smoothly move back and forth, and that the pin moves the entire length of the slot.

Solution

- Open the brass hex caps and inspect the rubber seals for wear. They may need to be replaced.
- Check that the hex cap (8.15) has a small hole through it to allow water to flow out of the piston. If this orifice is obstructed, remove debris.

6. PARTICLE REMOVER

Inspect the internal components for smooth operation. If the particle remover is jammed, this is your problem.

Solution

- Bypass the filter and relieve pressure. Open the connection clamp, and remove the top section of the filter. The particle remover should rotate freely inside the center of the plate.
- Remove the plate and inspect the particle remover. The rod should be inserted into the bushing near the inlet of the filter. There should be clearance between the suction nozzles and the screen.
- Check for any severe damage or wear on any of the components.

180 SERIES FILTER - NORMAL OPERATION

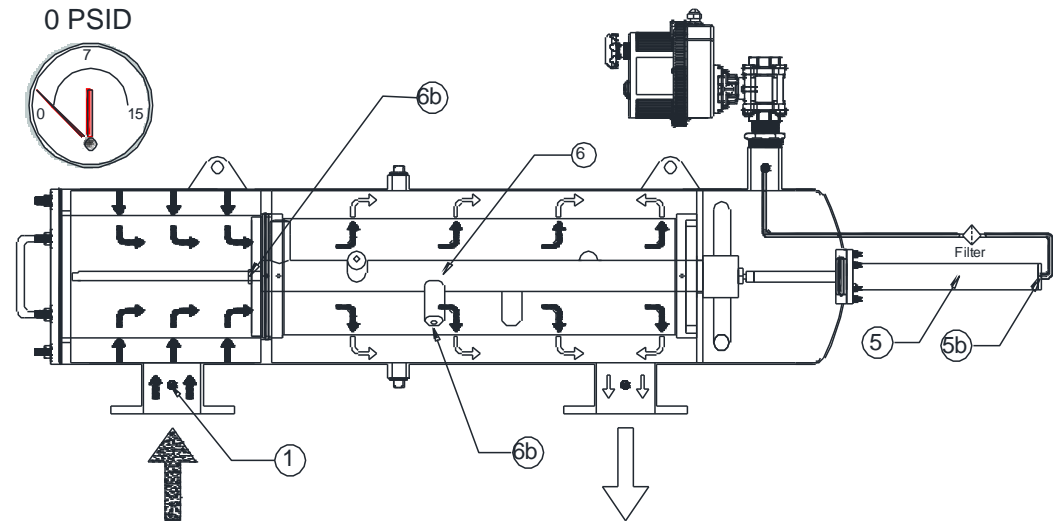

180 SERIES FILTER - BACKWASH CYCLE

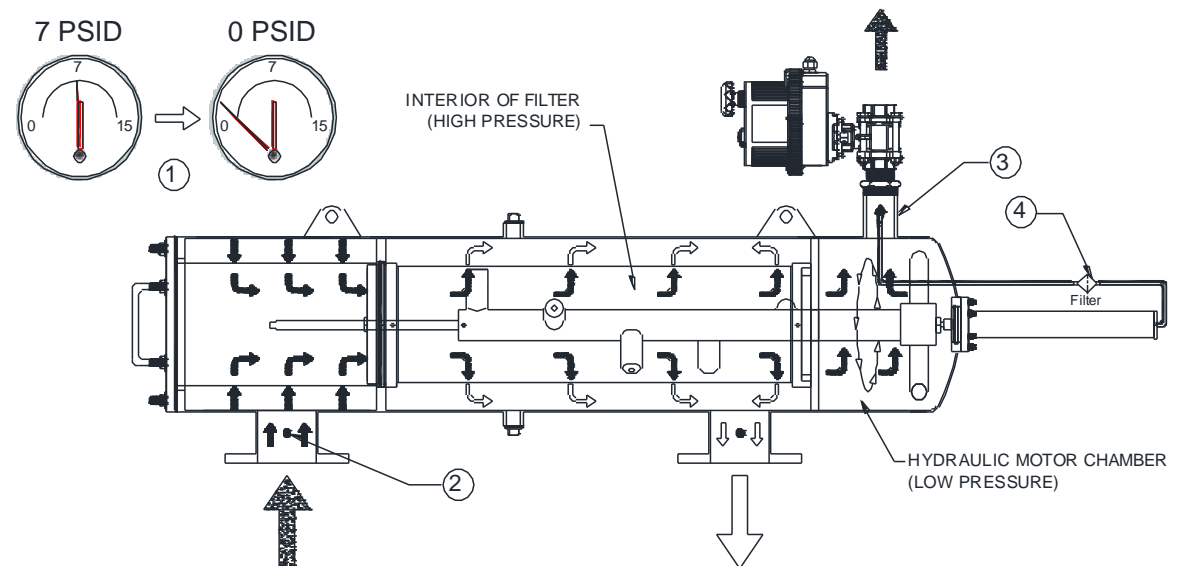
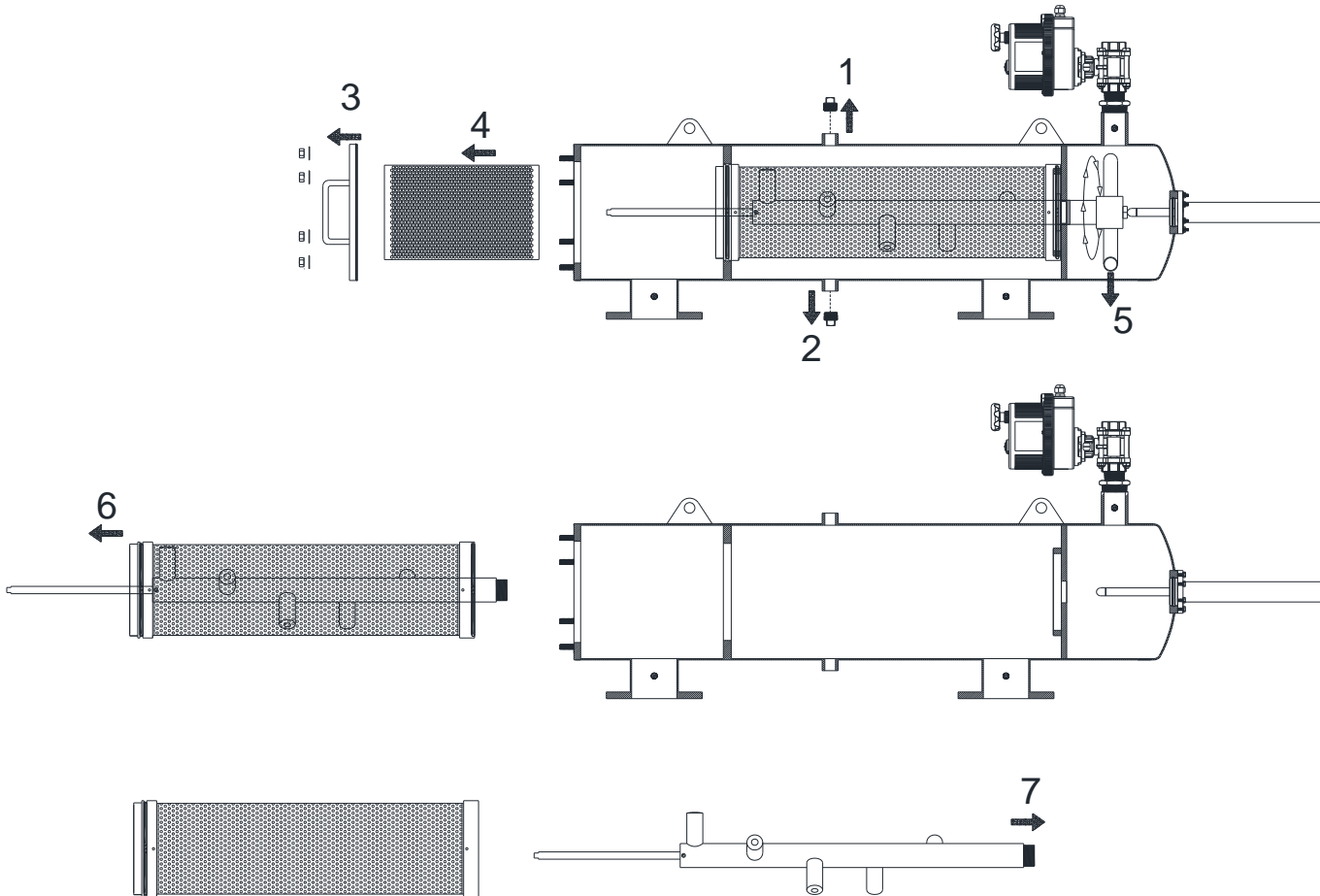

Figure 14: 180 Series Filter – Troubleshooting

Screen Removal Instructions



1. Relieve any static pressure in the filter body by running a backwash cycle and turning off the system once the gauge reads 0 psi. Once at 0psi, open the Coupling (N5). Verify an internal pressure lowered to atmosphere by looking at the gauges on the inlet and flush outlet.
2. Drain all excess water from the system through the hydraulic connection ports, piston connection or service ports
3. Remove the front plate from the body once all water is removed
4. Remove the coarse screen from inside the filter body and set aside for observation later
5. Open the service port furthest to the end of the body and unscrew the hydraulic motor. For this you will need to brace the particle remover and rotate the motor clockwise to remove. The motor is screwed in with left-hand-threading so ensure you are not tightening the motor even further
6. Remove the fine screen and particle remover all together by pulling on the screen bar
7. Separate the fine screen and particle remover by sliding the particle remover out of the screen

Figure 15: 180 Series Filter – Screen Removal

Screen Installation Instructions

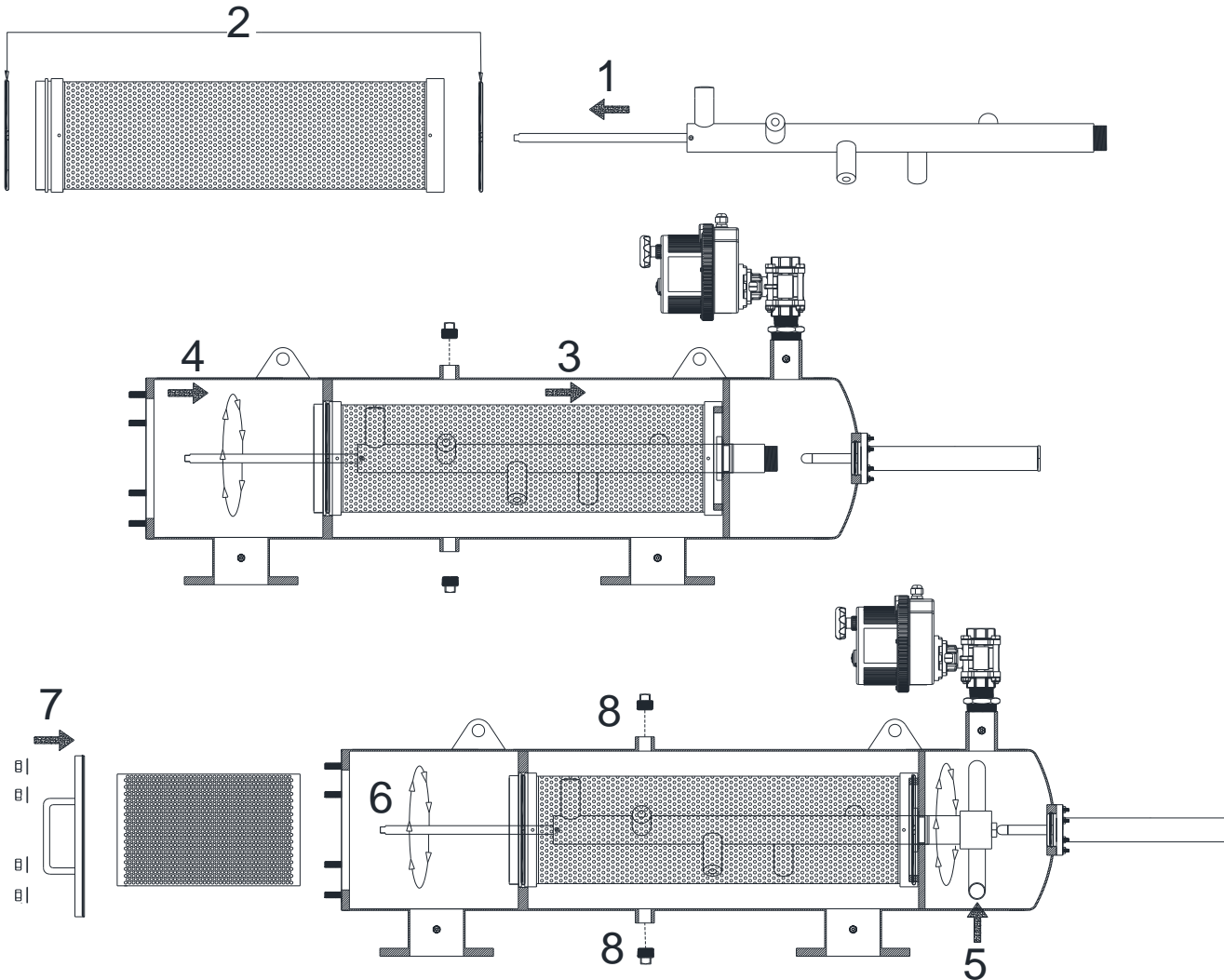

1. Insert the particle remover into the screen, guiding the rod into the screen bushing.
2. Lubricate the screen O-rings with NSF 61 approved silicone grease before installation .
3. Lift the fine screen with the particle remover as one unit and insert into the filter body. Guide the particle remover through the internal bushing at the opposite end of the filter body. Lift the screen as you guide it, end of the filter body
4. Hold the screen by the screen handles and rotate the screen 180 degrees as you push the screen into the body, allowing the screen to center itself. Once aligned, push the screen until it seals
5. Rotate the particle remover by hand ensuring unobstructed rotation
6. Install the hydraulic motor sprinkler by threading (left hand thread) it back into the particle remover through the service port. Close and secure the service port
7. Verify the cover seal is properly installed on the cover O-ring groove and secure the cover onto the studs with the washers and hex nuts. Follow a star pattern of fastening nuts
8. Reinstall the unplugged service ports, tighten down, verify they are all secure, and bring the filter back online. Inspect for any leaks.

Figure 16: 180 Series Filter – Screen Installation

INSTALLATION & WIRING

180 Series Filters Wiring

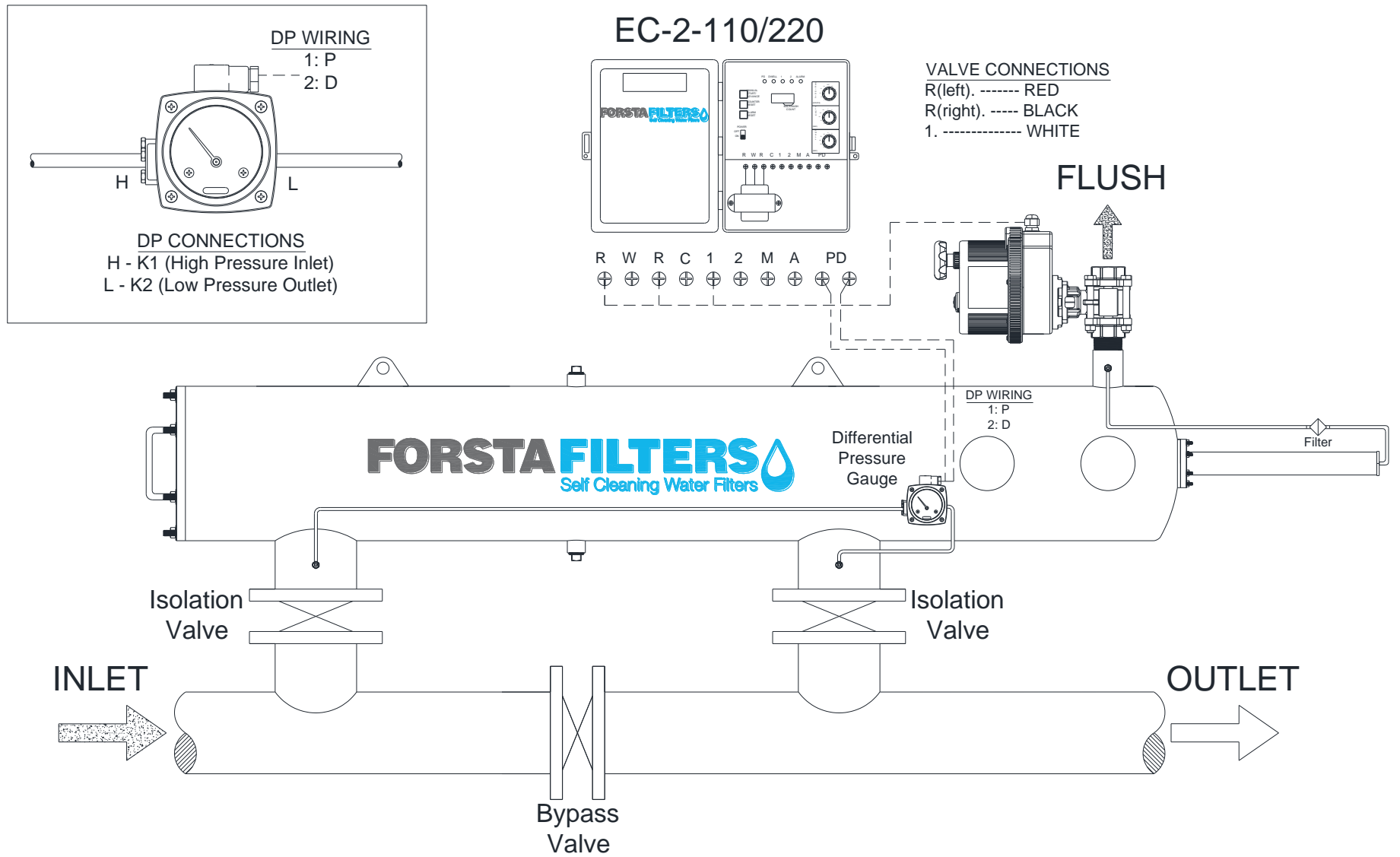

Figure 17: 180 Series Filter – EC-2 Wiring

2x180 Series Filters in Parallel

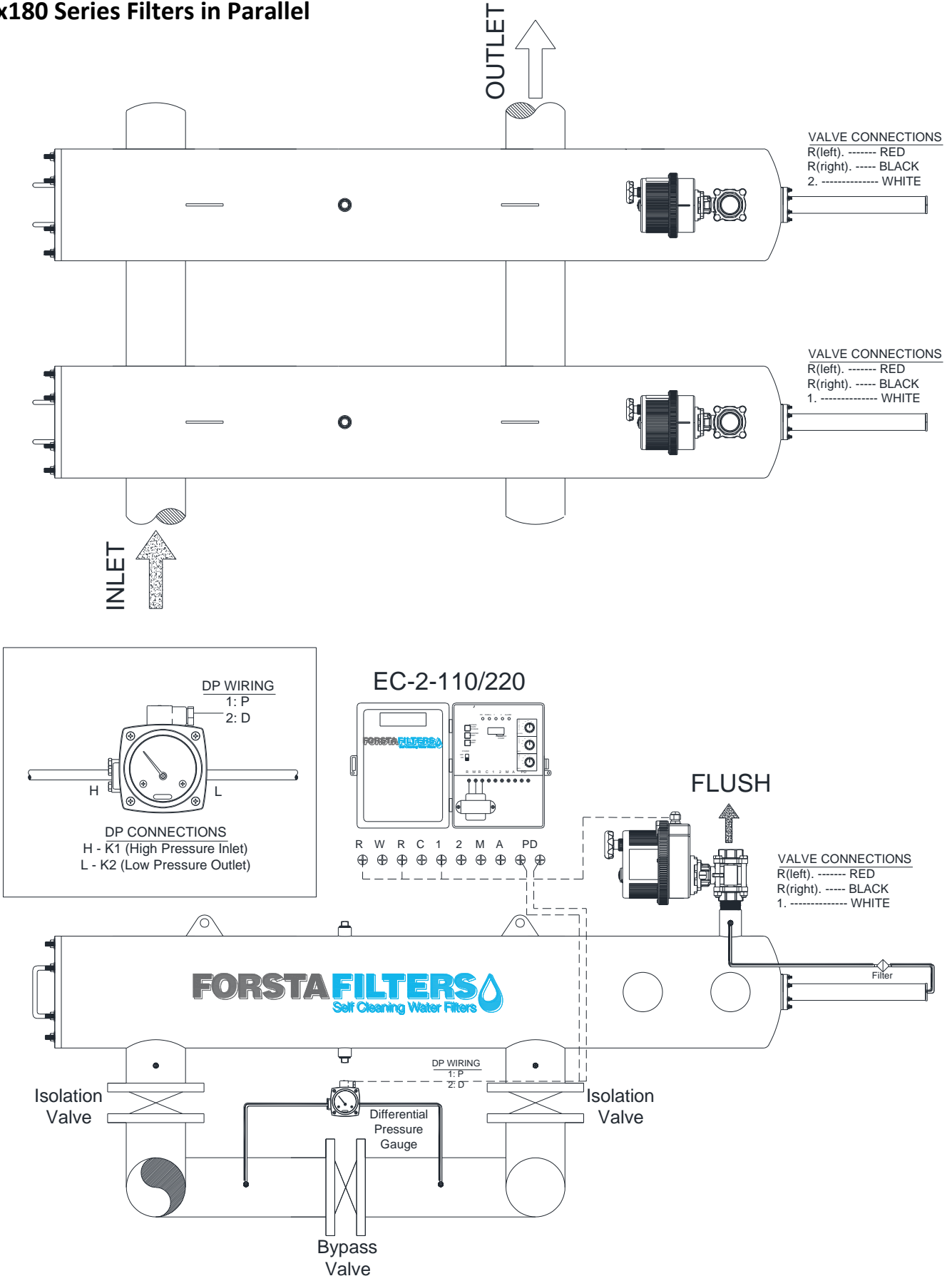

Figure 18: 180 Series Filter – 2x180 in Parallel

WARRANTY

Forsta Filters guarantees all self-cleaning water filters, components, and accessories free of defects for one year from the date of installation, or 18 months from the date of original shipment. Forsta will replace any part found defective during the warranty period, provided the equipment in question was handled, installed, and operated in accordance with the operation and maintenance manual and sound engineering practices. Forsta Filters assumes no liability for incidental or consequential damage resulting from the use of its products, services, or data. Liability is limited to replacement or repair of products provided by Forsta Filters, and no agent or sales representative has authority to extend the warranty period without the express written consent of Forsta Filters, Inc. Shipping charges for returned equipment will be at the expense of the purchaser, and all returned equipment must be sent to Forsta Filters