

## 90 SERIES OPERATION AND MAINTENANCE MANUAL

---



# TABLE OF CONTENTS

<b>FILTER BASICS</b> .....	1
<i>Figure 1: 90 Series Filter – General Layout</i> .....	1
<i>Figure 2: 90 Series Filter – Assembled View</i> .....	1
<i>Figure 3: 90 Series Filter – Exploded View</i> .....	2
<b>QUICK START GUIDE</b> .....	3
<i>Figure 4: 90 Series Filter – Quick Start Guide</i> .....	3
<b>INSTALLATION REQUIREMENTS</b> .....	4
<i>Figure 5: 90 Series Filter – Installment Layout</i> .....	4
Flush Line.....	4
Hydraulic Connections.....	5
Hydraulic Piston.....	5
<b>FILTER PERFORMANCE</b> .....	5
Normal Operation .....	5
<i>Figure 6: 90 Series Filter – Normal Operation</i> .....	5
Backwash Cycle .....	6
<i>Figure 7: 90 Series Filter – Backwash Cycle</i> .....	6
<b>FLOW &amp; PRESSURE REQUIREMENTS</b> .....	7
<i>Figure 8: 90 Series Filter – Valve Flow Rates</i> .....	7
<b>MAINTENANCE &amp; SPARE PARTS</b> .....	7
Startup.....	7
Shutdown .....	7
Periodic Maintenance.....	8
<i>Figure 9: 90 Series Filter – Inspection</i> .....	8
Particle Remover .....	9
<i>Figure 10: 90 Series Filter – Particle Remover</i> .....	9
Spare Parts.....	10
<i>Figure 11: 90 Series Filter – 2- 5-year Parts Maintenance</i> .....	10
Hydraulic Piston .....	11
<i>Figure 12: 90 Series Filter – Hydraulic Piston</i> .....	11
Piston Seal Replacement Instructions.....	12
<i>Figure 13: 90 Series Filter – Piston Seal Replacement</i> .....	12
Troubleshooting Guide .....	13
<i>Figure 14: 90 Series Filter – Trouble Shooting</i> .....	13
Screen Removal/Installation Instructions .....	14
<i>Figure 15: 90 Series Filter – Screen Removal</i> .....	14
<i>Figure 16: 90 Series Filter – Screen Installation</i> .....	15
<b>INSTALLATION &amp; WIRING</b> .....	16
90 Series Filters Wiring .....	16
<i>Figure 17: 90 Series Filter – EC-2 Wiring</i> .....	16
2x90 Series Filters in Parallel .....	17
<i>Figure 18: 90 Series Filter – 2x90 in Parallel</i> .....	117
<b>WARRANTY</b> .....	18

# FILTER BASICS

The Forsta 90 Series are self-cleaning screen water filters. The major components include the Filter Housing (1), Fine Screen filter element (2), Particle Remover (3), Hydraulic Piston (8), and Backwash Valve (12)

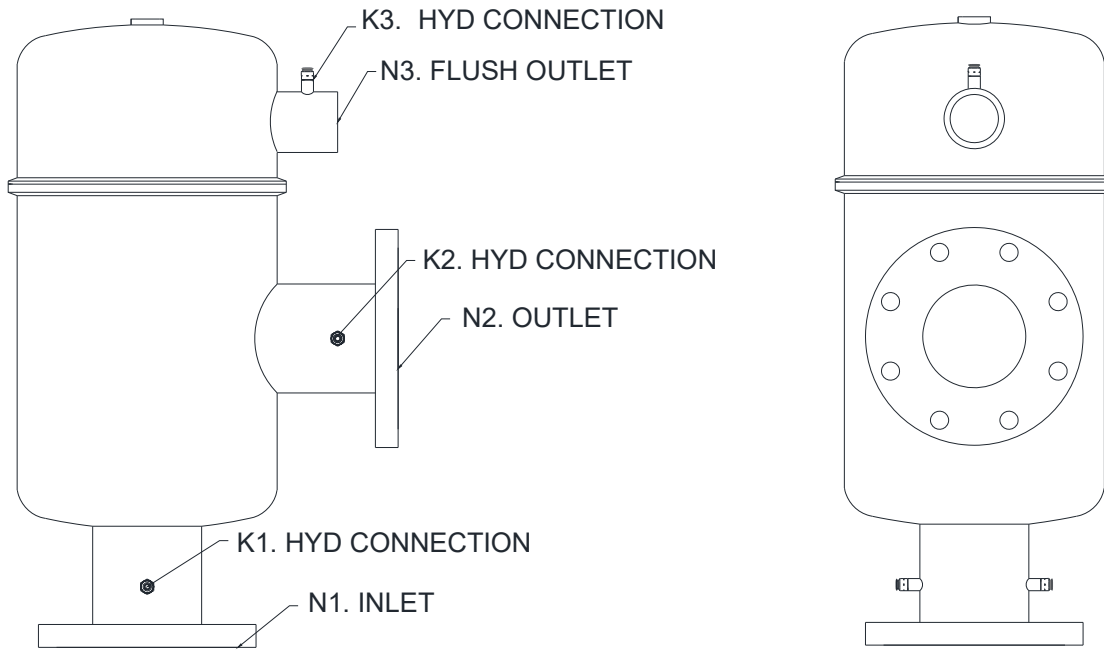

Figure 1: 90 Series Filter – General Layout

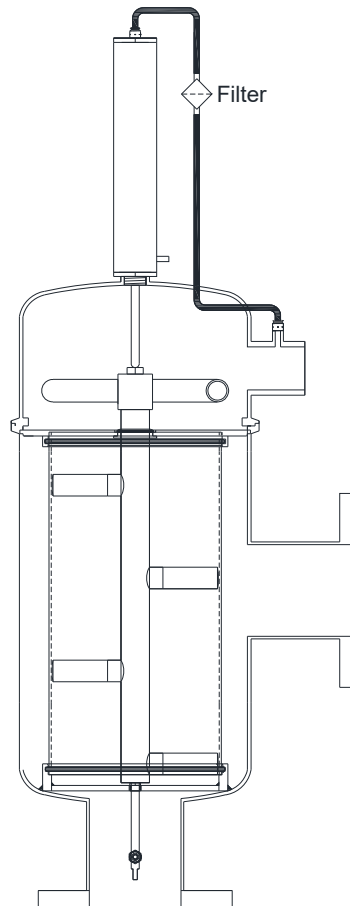

Figure 2: 90 Series Filter – Assembled View

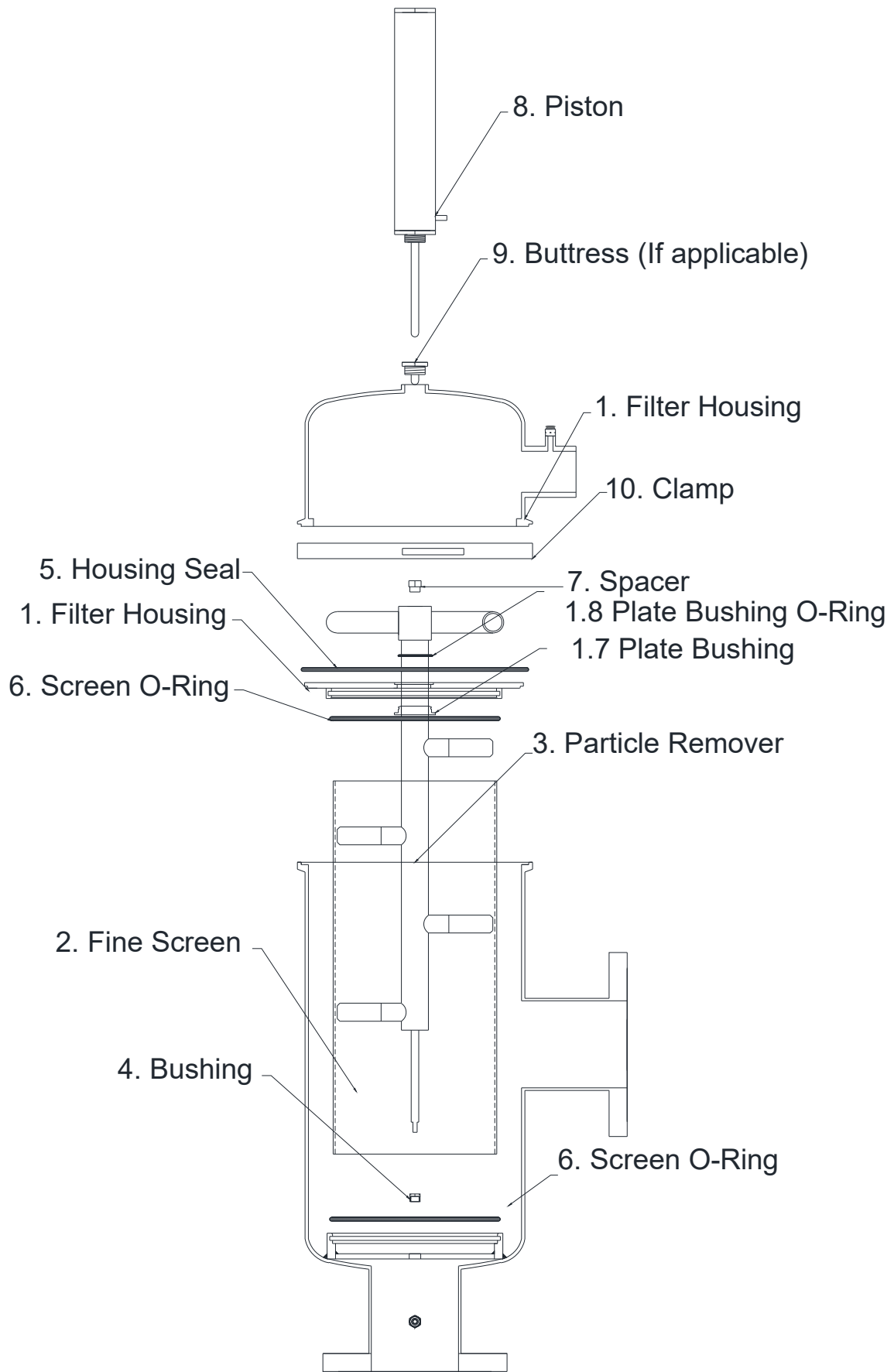

Figure 3: 90 Series Filter - Exploded View

# QUICKSTART GUIDE

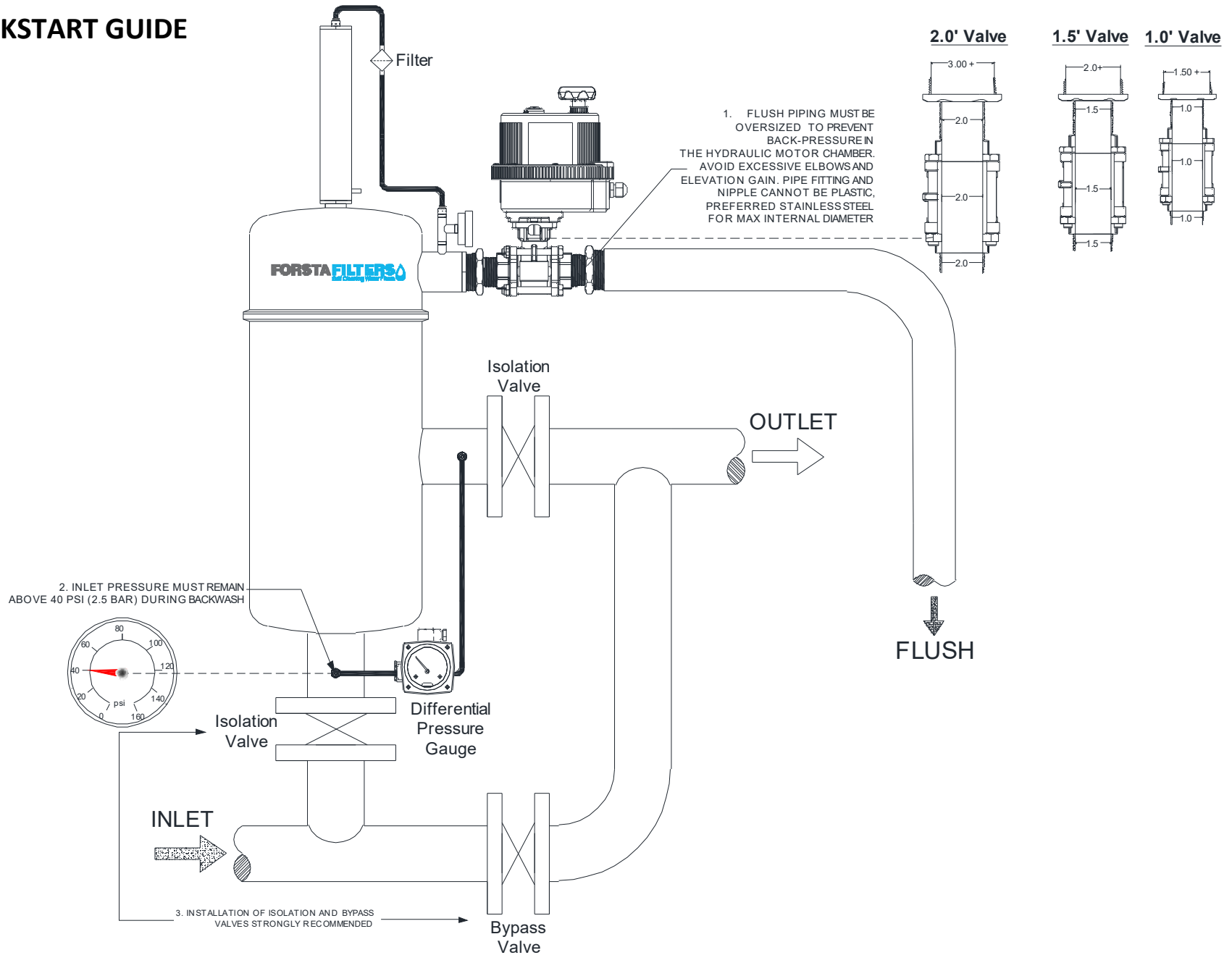
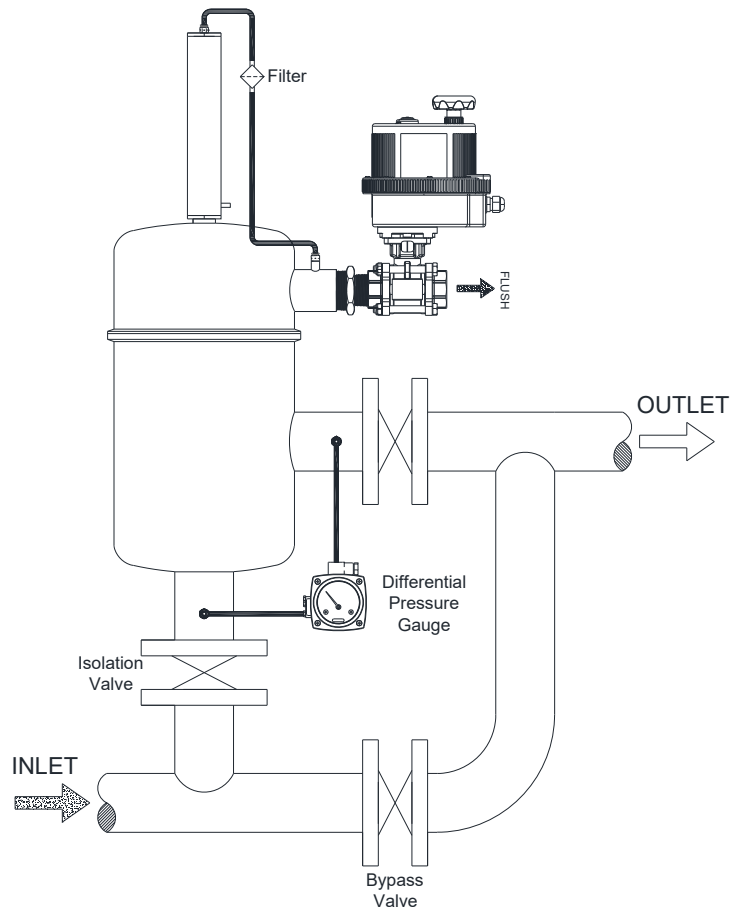

Figure 4: 90 Series Filter – Quick Start Guide

## INSTALLATION REQUIREMENTS

90 Series filters may be mounted directly on the inlet (N1) and outlet (N2) flanges, and positioned in any orientation. As shown below in figure 4, isolation valves should be installed at the inlet and outlet, and a bypass valve should be installed between the flanges. This will allow the filter to be taken offline without disruption to water flow.



*Figure 5: 90 Series Filter – Installment Layout*

There should be adequate clearance around the filter to allow for easy maintenance access. Ensure there is enough space above the filter, the top (cover), to access every component with ease and remove the fine screen periodically.

### Flush Line

The piping for the flush valve must have no backpressure. It is strongly recommended to use oversized piping to accommodate this requirement. For example, if the 90 Series filter uses a 1" valve, the recommended pipe is a minimum of 1.5".

To minimize backpressure on the flush line, it is also important to avoid elevation gain in the flush line. Even small elevation gains will reduce the filter's ability to perform an effective backwash cycle. If flush water must be transported to higher elevation, it is recommended to pipe the flush line to a storage tank first, and then pump it out to higher elevation. Additionally, avoid any sharp bends and shifts of direction to allow a smooth flow of water during backwash.

## Hydraulic Connection

Each flanged connection nozzle (N1) on the 90 Series filter has two ¼" threaded couplings. One may be used to install a pressure gauge or other sensor equipment. The other ¼" coupling will be used to connect hydraulic tubing from the differential pressure switch to the filter. The high-pressure line is fitted to the inlet, and low pressure fitted to the outlet.

## Hydraulic Piston (if applicable)

The piston (8) is mounted on the domed end of the filter. ¼" tubing must be installed from the fitting located on the back of the piston to the hydraulic connection (K3) on the flush outlet (N3). A filter is installed on the hydraulic tubing to protect the piston.

## FILTER PERFORMANCE

### Normal Operation

During normal operation of the filter, dirty water enters through the inlet and passes through the coarse screen. Any abnormally large debris is caught here and prevented from possibly damaging the fine screen or particle remover.

Water then travels down the center of the filter and is strained across the fine screen. As water passes from inside the screen to outside, suspended particles are trapped on the fine screen and continue to buildup, eventually creating a drop in pressure at the outlet of the filter.

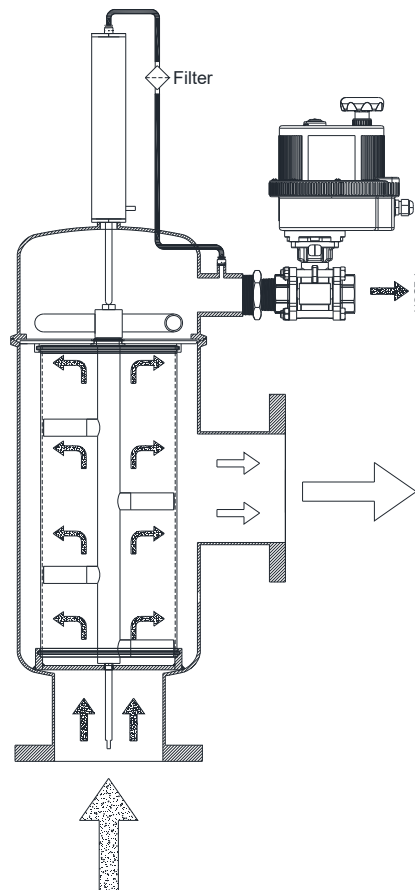
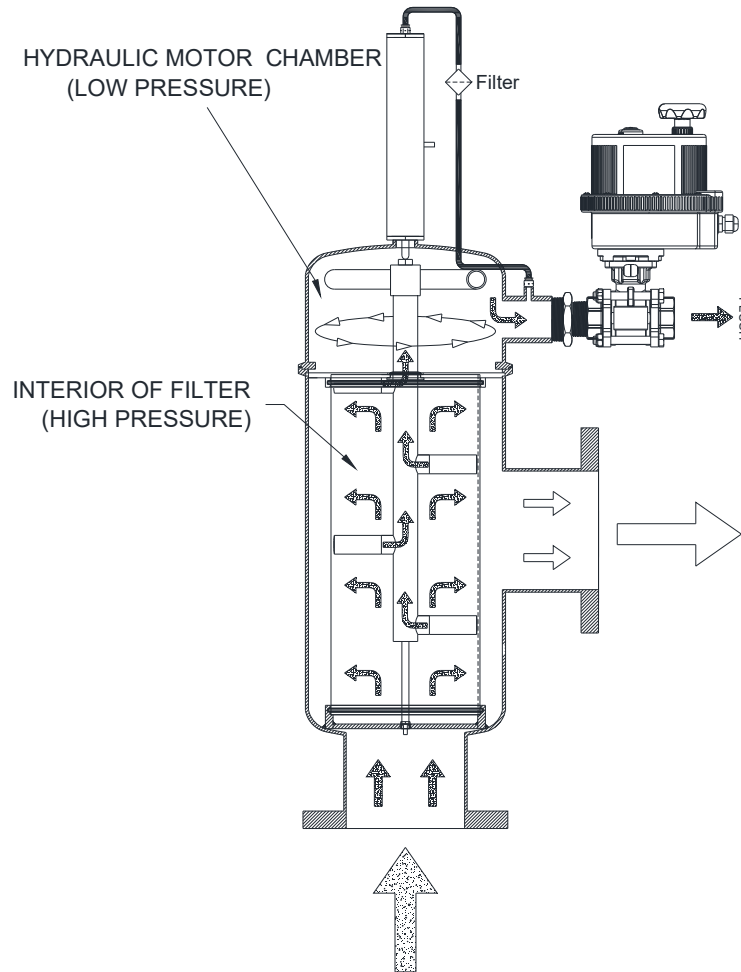

Figure 6: 90 Series Filter – Normal Operation

This drop in outlet pressure is monitored by the differential pressure gauge, which at seven PSID (pounds per square inch differential) sends a signal to the controller to initiate a backwash cycle.

## Backwash Cycle

The controller opens the flush valve, which causes a drop in pressure in the hydraulic motor chamber. This creates a low-pressure path inside the particle remover, which acts as a vacuum at the end of the suction nozzles, removing the built-up debris from the inside of the fine screen.



*Figure 7: 90 Series Filter – Backwash Cycle*

Water flows through the suction nozzles, down the interior of the particle remover, and out the hydraulic motor. The motor rotates the particle remover, enabling each suction nozzle to cover a radial strip of screen. And the pressure difference between the interior of the filter and the hydraulic motor chamber drives the particle remover toward the hydraulic piston.

The piston depressurizes during the backwash cycle, and expels the volume of water from its chamber. This acts as a timer, gradually allowing the particle remover to drive the piston rod into the piston, assuring that the suction nozzles cover the entire surface of the fine screen. When the piston reaches the end of its stroke, the backwash cycle is complete, and the flush valve closes. Pressure inside the hydraulic motor chamber normalizes with the rest of the filter, and the piston pushes the particle remover back to its original position.

After the piston and particle remover move back to their original positions, the filter returns to normal operation. During the entire backwash cycle, the main flow through the filter is never disrupted.



## FLOW & PRESSURE REQUIREMENTS

Forsta 90 Series filters have a minimum pressure requirement of 40 PSI. This includes any pressure loss incurred during the backwash cycle. Therefore, the pump performance is a crucial component in determining whether the filter will perform correctly.

Pump manufacturers will provide the performance data in the form of a pump curve. This is a graph that plots pressure vs. flow rate. A pump is considered adequate for an application if it can maintain a minimum of 40 PSI while pumping the normal system flow AND the additional flow required during backwash. The additional flow depends on the filter model and what valve is used.

<u>Valve</u>	<u>Flow Rate</u>
1"	40-60 gpm
1.5"	100 gpm
2	220 gpm

*Figure 8: 90 Series Filter – Valve Flow Rates*

## MAINTENANCE & SPARE PARTS

### Startup

When pumping water through the Forsta 90 Series for the first time or after it has been empty, it is important to follow a correct sequence of valve actuation in order to prevent damage to the filter components.

With both isolation valves closed and the bypass valve open, the correct sequence is:

1. Slowly open the inlet isolation valve letting water flow into the filter. If installed, bleed out the air through a valve on the top of the filter body. Let the entire filter fill with water before moving to the next step.
2. Close the bypass valve.
3. Open the outlet isolation valve.

If it is not an option to close the bypass valve momentarily before opening the outlet valve, then both may be actuated simultaneously.

### Shutdown

To remove the filter from operation, reverse the steps used for startup.

1. Close the outlet valve.
2. Open the bypass valve
3. Close the inlet valve, and slowly open the drain valve on the bottom of the filter housing. There will be residual pressure in the tank still, so use caution when draining.

If it is not an option to close the outlet valve momentarily before opening the bypass, then both may be actuated simultaneously.

## Periodic Maintenance

Every six months, or whenever pumps or water flow is shutdown, it is recommended to open and inspect the filter components. Access to the internal components can be gained by removing the clamp and top section of the filter body. Simply remove the top, lift the particle remover and plate out of the filter housing and separate into two components. Inspect both for wear.

Remove the piston from the back plate and drain the water from the piston chamber. Verify that the piston rod is moving smoothly in and out, and inspect the piston tip for wear.

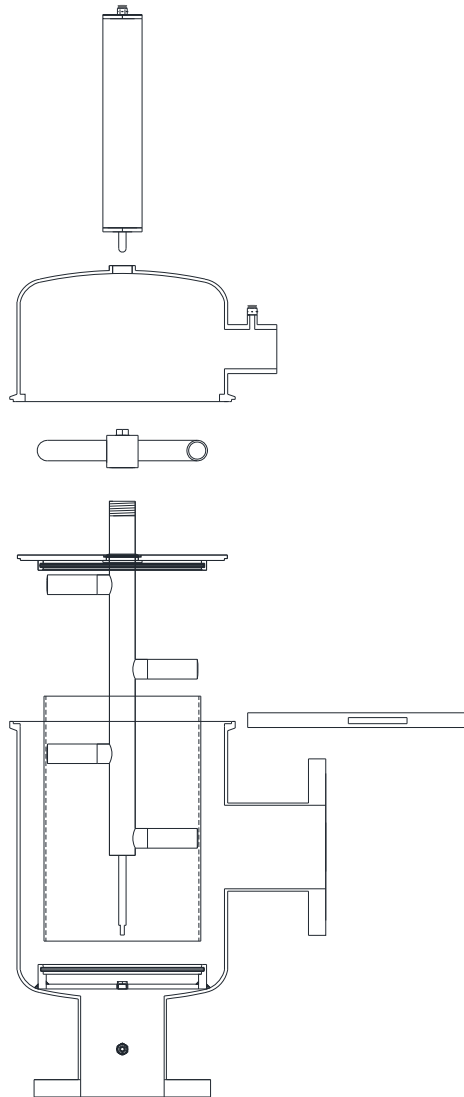

*Figure 9: 90 Series Filter - Inspection*

Remove the screen and particle remover, using the front cover for access. Both should be extracted in one piece. Separate the two items and inspect both for damage. The screen mesh and bushing should be inspected for wear. Also inspect the particle remover rod and suction nozzles for wear.

When taking care of the filter, also perform the same periodic maintenance on the piston itself. A step-by-step description of disassembling the piston for maintenance and replacement of parts is displayed on page 12 of the manual.

Particle Remover

3 Particle Remover

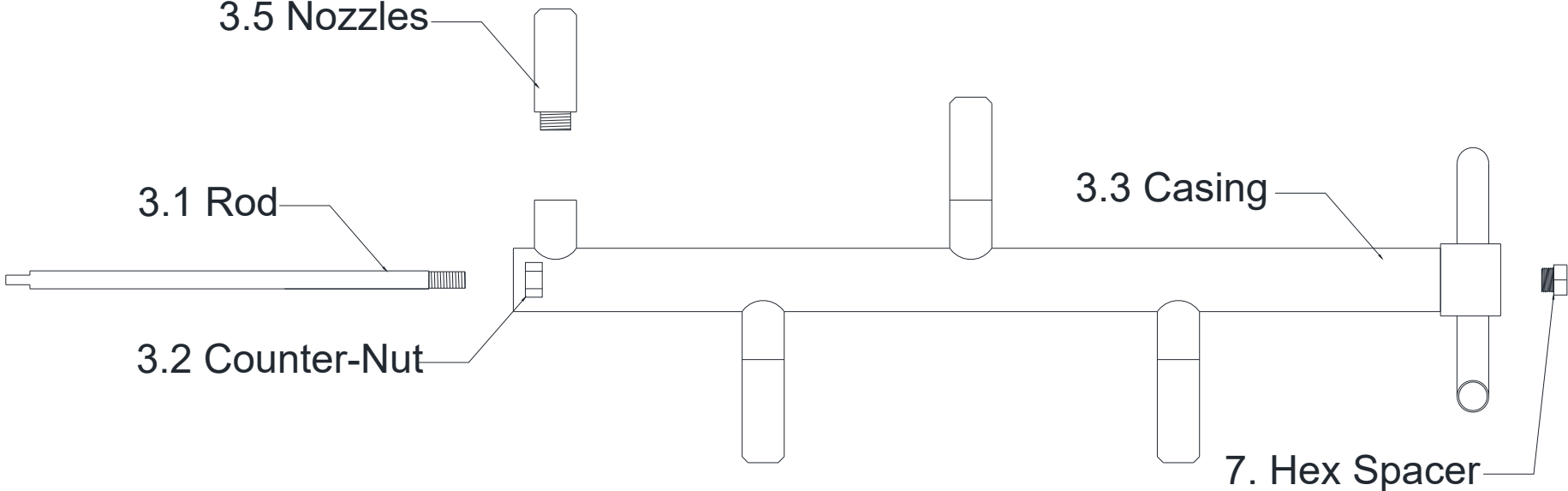

Figure 10: 90 Series Filter – Particle Remover

## Spare Parts

Spare parts for maintenance for **two** years include:

Part Number	Description	Qty
1.7-90/180C/LP180C-UHMWPE	Plate Bushing	1
1.8-90/180C/LP180C-UHMWPE	Plate Bushing O-Ring	1
16-1/4	Mini Filter	1
17-Fitting/Tubing	Fitting Tube	1
18-D/P-MW-522A	Pressure Differential Switch	1
3.5-90/180C	Suction Nozzles	3-5
4-90/180C/LP180C-VHL	Stainless Steel Bushing	1
5-90/180C/LP180C	Housing Seal	1
6-90/180C/LP180C	Screen O-Ring	2
7-90/180C-316L-VES	Spacer	1
8K-90/180C	Piston Repair Kit	1
10-90/180C/LP180C	Stainless Steel Clamp	1

Spare parts for maintenance for **five** years include:

Part Name	Qty
Plate bushing (1.7)	2
Plate bushing o- ring (1.8)	2
Fine Screen (2)	1
Particle Remover (3)	1
Particle Remover rod (3.1)	1
Suction Nozzles (3.5)	2 Sets
Bushing (4)	2
Cover Seal (5)	2
Screen O-rings (6)	4
Hex Spacer (7)	2
Hydraulic piston (8)	1
Shaft tip (8.9)	2
Piston Seal Kit (8K)	2
Valve (12)	1
Mini-Filter (16)	2
Differential Pressure Gauge (18)	2
Tubing & fitting	2

Figure 11: 90 Series Filter – 2- and 5-Year Parts Maintenance

# Hydraulic Piston

8

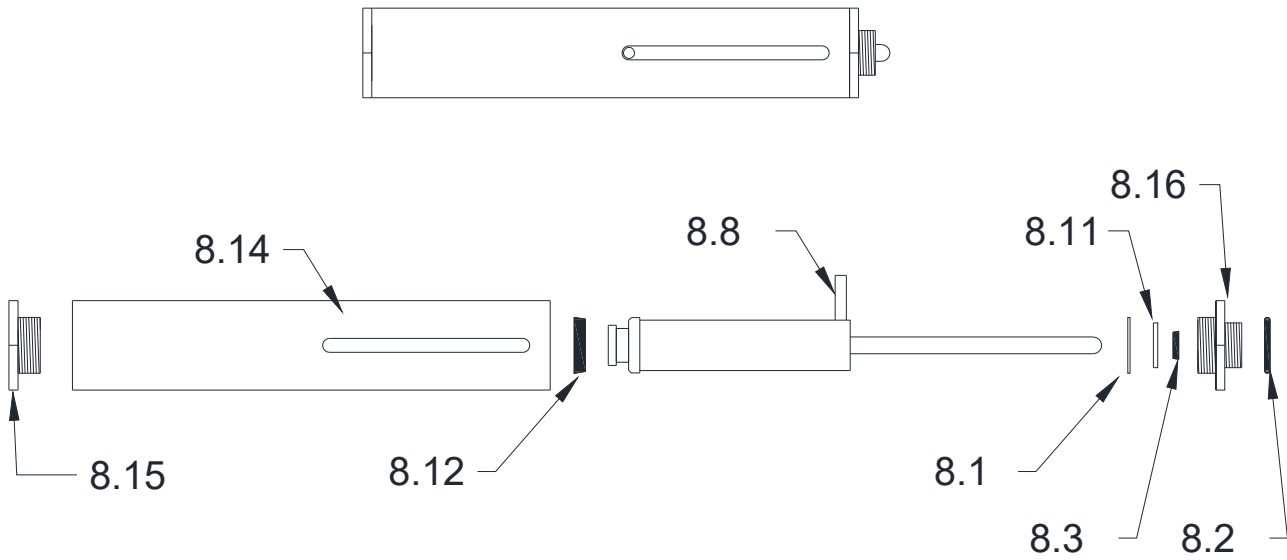

ITEM	PART NUMBER
Hydraulic Piston	8
Snap Ring	8.1
Head Ring	8.2
Shaft U-cup	8.3
Piston Pin	8.8
U-cup Holder	8.11
Casing U-cup	8.12
Casing	8.14
Casing Cap	8.15
Piston Head	8.16

Figure 12: 90 Series Filter – Part List – Hydraulic Piston

## Piston Seal Replacement Guide

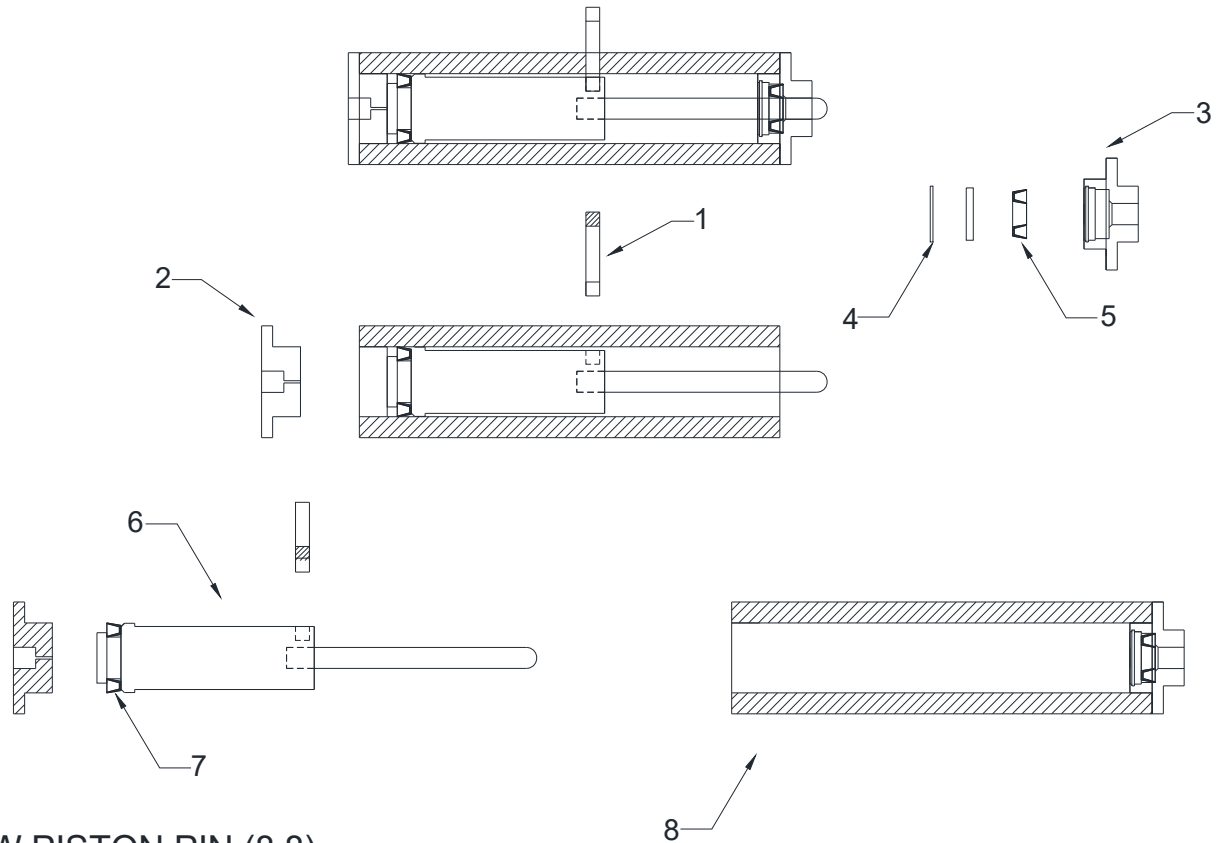

1. UNSCREW PISTON PIN (8.8)
2. UNSCREW PISTON CAP (8.15)
3. UNSCREW PISTON HEAD (8.16)
4. USE C-RING PLIERS TO REMOVE CLAMP AND HEAD WASHER (8.1)
5. REPLACE SHAFT U-CUP (8.3)
6. REMOVE U-CUP HOLDER (8.11)
7. REPLACE CASING U-CUP (8.12)
8. CLEAN AND LUBRICATE CASING (8.14) USING MOLYKOTE 111 OR SILICONE GREASE

Figure 13: 90 Series Filter – Piston Seal Replacement

# Troubleshooting Guide

## 1. PRESSURE

Record the pressure reading at inlet connection K1. If the pressure is below 40 psi, this is your problem.

### Solution

Increase system pressure by:

- Choking the outlet of the filter.
- Ramping up pump.
- Replacing pressure gauge if it is defective.

## 2. BACKWASH PRESSURE

Record the pressure reading at inlet connection K1 during backwash (flush valve open). If the pressure is below 40 psi, this is your problem.

### Solution

Increase system pressure by:

- Choking the outlet of the filter.
- Ramping up pump.
- Replacing pressure gauge if it is defective.

## 3. FLUSH PORT

Record the pressure reading at flush outlet connection K3 during backwash. If no pressure gauge is installed on K3, add a tee ("T") connection to install gauge. If the pressure does not read 0 psi during backwash, this is your problem.

### Solution

- Re-pipe the flush line to prevent back-pressure. Remove elbows, elevation gain, and oversize the pipe.
- Flush directly to a nearby tank.
- Increase flush valve size from 1" to 2".

## 4. MINI FILTER

Inspect mini-filter located on the piston tubing line. If the mini-filter is clogged, this is your problem.

### Solution

- Wash the mini-filter.

## 5. HYDRAULIC PISTON

Inspect the hydraulic piston (8). Verify that the rod can smoothly move back and forth, and that the pin moves the entire length of the slot.

### Solution

- Open the brass hex caps and inspect the rubber seals for wear. They may need to be replaced.
- Check that the hex cap (8.15) has a small hole through it to allow water to flow out of the position. If this orifice is obstructed, remove debris.

## 6. PARTICLE REMOVER

Inspect the internal components for smooth operation. If the particle remover is jammed, this is your problem.

### Solution

- Bypass the filter and relieve pressure. Open the connection clamp, and remove the top section of the filter. The particle remover should rotate freely inside the center of the plate.
- Remove the plate and inspect the particle remover. The rod should be inserted into the bushing near the inlet of the filter. There should be clearance between the suction nozzles and the screen.
- Check for any severe damage or wear on any of the components.

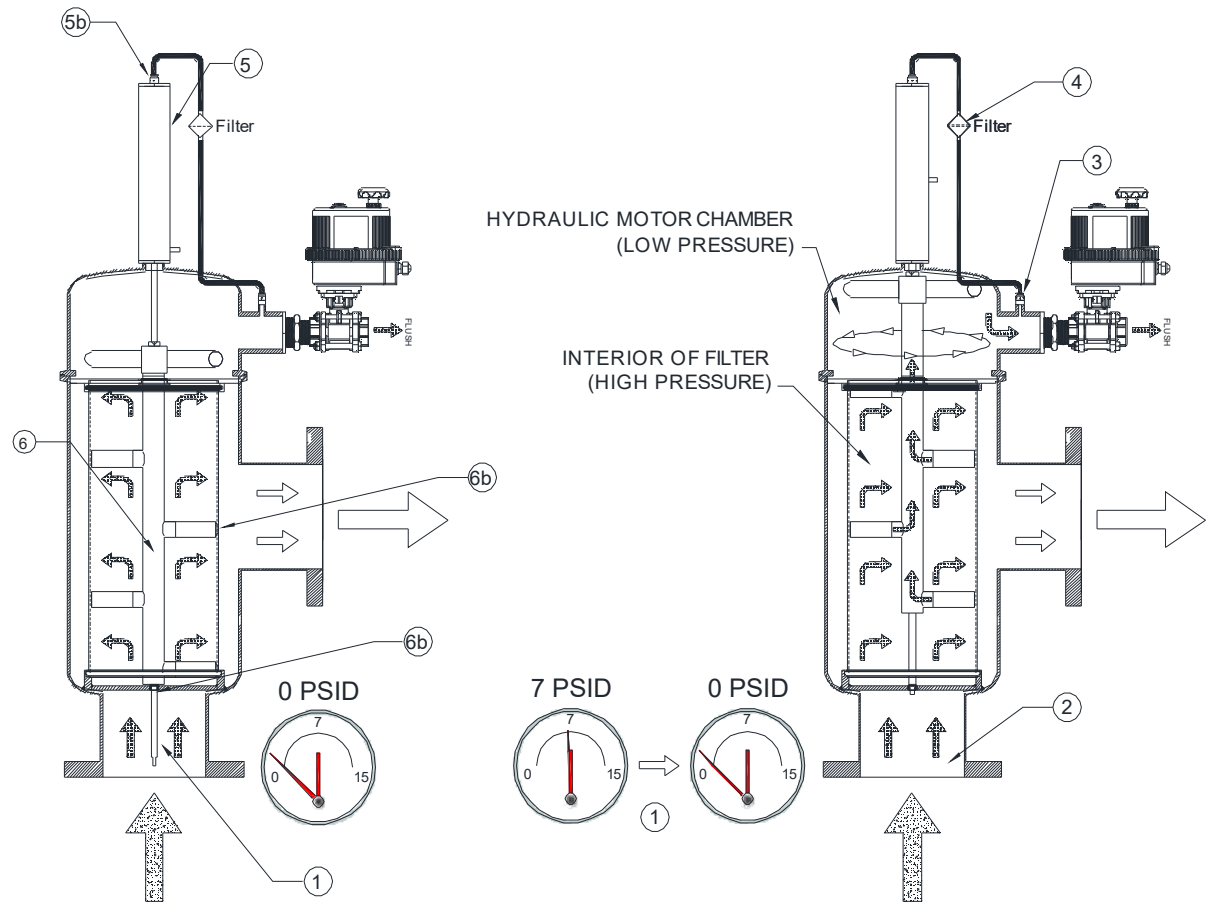

### NORMAL OPERATION

Debris is trapped as water passes through the inlet and across the fine screen. Clean water exits through the outlet of the filter.

### BACKWASH CYCLE

The flush valve opens and lowers the pressure in the top section. This causes the particle remover to vacuum the inside of the screen, expelling debris through the flush outlet.

Figure 14: 90 Series Filter – Troubleshooting

## Screen Removal Instructions

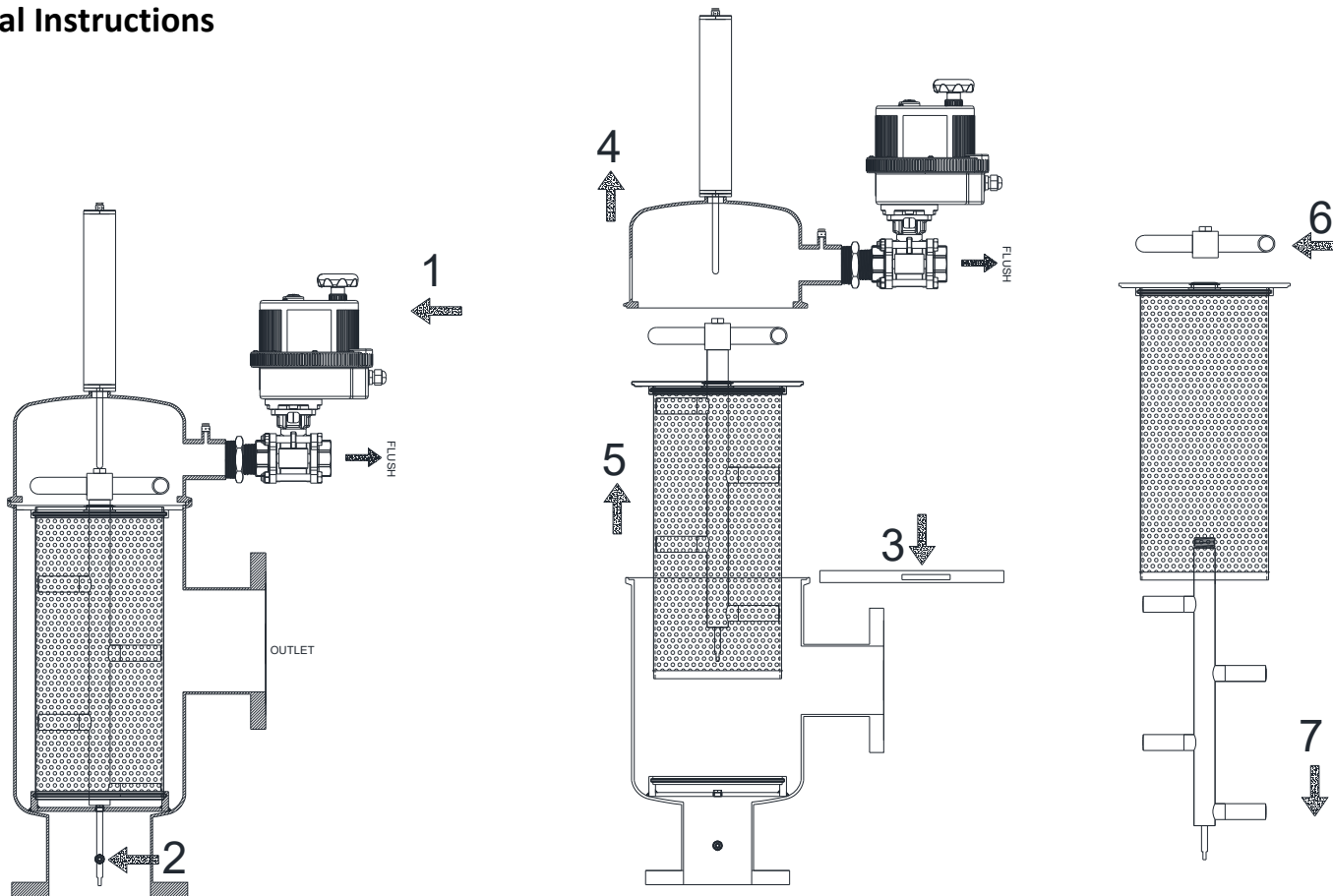

1. Relieve pressure in the filter body by first running a backwash cycle. Monitor the pressure gauge and stop once 0 PSI is reached.
2. Drain the filter body by removing the fittings on the inlet pipe.
3. Remove the clamp holding the top cap and filter body together
4. Remove the entire system of filter cap, piston, and valve all together
5. Remove the particle remover and fine screen system together
6. Remove the hydraulic motor sprinkler. Keep in mind it is a left hand thread.
7. Separate the particle remover and fine screen while examining any contamination or damage reports.

Figure 15: 90 Series Filter – Screen Removal



## Screen Installation Instructions

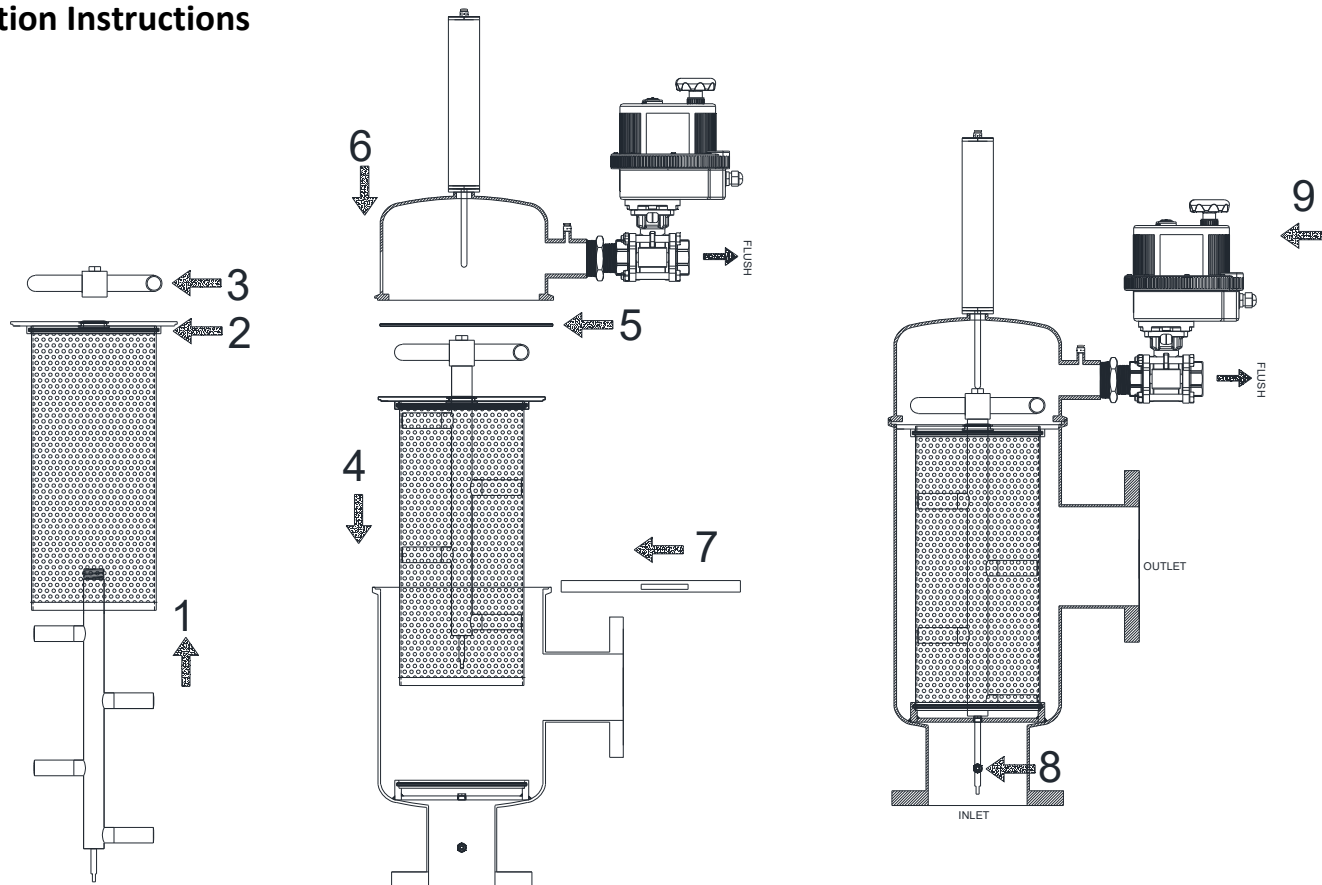

1. Insert the particle remover into the screen, guiding the particle remover through the bushing
2. Lubricate the screen O-rings with NSF 61 approved silicone grease before installation
3. Install the sprinkler for the hydraulic motor
4. Place the fine screen and particle remover system into the filter body
5. Lubricate and place cover seal O-ring with the same NSF 61 approved silicone grease.
6. Place the lid with the piston and valve onto the filter body to close off the filter
7. Place the clamp around and secure the lid and filter body very tightly
8. Install the fitting in the hydraulic connection that was taken out to drain the filter body
9. Run the system's backwash cycle and ensure there is no leaks before returning to regular functionality

Figure 16: 90 Series Filter – Screen Installation





## **WARRANTY**

Forsta Filters guarantees all self-cleaning water filters, components, and accessories free of defects for one year from the date of installation, or 18 months from the date of original shipment. Forsta will replace any part found defective during the warranty period, provided the equipment in question was handled, installed, and operated in accordance with the operation and maintenance manual and sound engineering practices. Forsta Filters assumes no liability for incidental or consequential damage resulting from the use of its products, services, or data. Liability is limited to replacement or repair of products provided by Forsta Filters, and no agent or sales representative has authority to extend the warranty period without the express written consent of Forsta Filters, Inc. Shipping charges for returned equipment will be at the expense of the purchaser, and all returned equipment must be sent to Forsta Filters